



FOR A GREEN WORLD

OPERATING MANUAL

for

RAINSTAR

Series T32, T42



Version III – 2017
Art. Nr. 827 9980

RAINSTAR
T32, T42
E

Introduction

Thank you for buying BAUER RAINSTAR T !

The present **manual** is a very important document that describes how to operate and **BAUER RAINSTAR T**.

This manual describes the system as detailed as possible. If you need still more information, please contact your dealer or turn directly to **BAUER** in Voitsberg/Austria.

Please note that the content of this manual neither constitutes part of nor alters in any way any previous or existing agreement, promise or legal relationship. **BAUER's** commitment is based solely on the respective purchase contract which also contains the complete and only valid warranty agreement. Said contractual warranty is neither extended nor limited by the content of this manual.

All information contained in the present manual is based on the latest product details available at the time of printing.

BAUER reserves the right to change without notice without assuming any liability!

BAUER RAINSTAR T is designed for highest performance safety and reliability provided it is operated in accordance with the present operating instructions.

Therefore you should study this manual thoroughly before starting your **BAUER RAINSTAR T** !

Strictly observe all instructions pertaining to system handling, operation and service!

On this condition, **BAUER RAINSTAR T** will operate to your satisfaction for many years!



Non-observance of this manual may cause personal injury or damage the equipment!

This manual is to be considered an integral part of **BAUER RAINSTAR T**. Suppliers of both new and used systems are advised to put down in writing that they delivered the manual together with the system.

Please make this manual available to your staff. State the pump type and serial number of your **BAUER RAINSTAR T** in all inquiries, correspondence, warranty problems, or parts orders.

We wish you a lot of success with BAUER RAINSTAR T !

Product details

Type designation: **BAUER RAINSTAR T**

Model: Series T32, T42

Serial number¹: _____

Dealer: Name: _____

Address: _____

Tel./Fax: _____

Date of shipment: _____

Manufacturer: Röhren- und Pumpenwerk **BAUER** Ges.m.b.H.
Kowaldstr. 2
A - 8570 Voitsberg/Austria
Tel.: +43 3142 200 - 0
Fax: +43 3142 200 -320 /-340
e-mail: sales@bauer-at.com
www.bauer-at.com

Owner or user:: Name: _____

Address: _____

Tel. / Fax: _____

Note: Please make a note of the type and serial number of your BAUER RAINSTAR T and its accessories! Be sure to state these details every time you contact your dealer.

¹ It is very important to register the complete serial number (the sticker is placed inside the control panel) of the machine and its individual components. Please specify this number in all warranty matters and correspondence relating to this machine.

Index

1	GENERAL INSTRUCTIONS	8
2	GENERAL	9
3	SAFETY	9
4	WARNING SYMBOLS	12
5	DESCRIPTION	13
6	PUTTING INTO OPERATION	14
6.1	PREPARATIONS FOR THE RUN.....	19
6.2	MACHINE TRANSPORT TO SETTING-UP POSITION.....	19
6.3	OPERATING MODE I: PE-PIPE PULL-OFF	20
6.3.1	MACHINE SET-UP	20
6.3.2	LOWERING THE CART	21
6.3.3	checking THE SHUT-OFF	22
6.3.4	PE-PIPE PULL-OFF.....	22
6.4	OPERATING MODE II: LAYING DOWN THE PE-PIPE.....	23
6.5	SETTING OF TURBINE REGULATION.....	23
6.6	STARTING PE-PIPE RETRACTION.....	24
6.7	RETRACTION STOP, RESTART (EMERGENCY SHUT-OFF).....	25
6.8	PTO REWIND:.....	25
7	ECOSTAR 4300	26
7.1	GENERAL.....	26
7.2	DISPLAY WINDOWS AND MENU OVERVIEW.....	27
7.3	PROGRAMMING OF 4 DIFFERENT SPEEDS.....	31
7.4	STATUS DISPLAY.....	32
7.5	THE MOST COMMON COMBINATION OF DIFFERENT CONSTANTS	33
7.6	STOP - SENSOR.....	34
7.7	OPERATION OF THE BAUER ECOSTAR 4300	35
7.7.1	SPEED ADJUSTMENT.....	36
7.7.2	PRE – OR POST IRRIGATION	36
7.7.3	START	37
7.7.4	MONITORING.....	37
7.7.5	STOP.....	38
7.8	PRESSURE SWITCH (OPTIONAL EQUIPMENT).....	39
7.9	ERROR DESCRIPTION – ECO STAR 4300.....	39
7.10	PROGRAMMING PROCEDURE.....	40
7.11	BATTERY.....	43
7.11.1	SOLAR PANEL	44
7.11.2	CHECKING THE CONNECTIONS.....	44
7.11.3	CHECKING THE LENGTH SENSOR.....	44
7.11.4	LIMIT STOP FOR TURBINES – REGULATING VALVE WITH ECOSTAR 4300.....	45
7.11.5	SHORT CHECKLIST FOR ECOSTAR 4300	45
8	OPTION - SMS	46
9	CABLE CONNECTIONS –CONNECTION DIAGRAM	50
9.1	CHECKLIST FOR ECOSTAR 4300.....	52

9.2	TABLE FOR PRE-AND POST-IRRIGATION	56
10	WINDING MECHANISM	57
10.1	ADJUSTMENT OF THE WINDING MECHANISM	57
11	SHUT-OFF AND SAFETY EQUIPMENT	60
11.1	SETTING INSTRUCTIONS FOR SHUT-OFF	60
11.2	SETTING THE SHIFTING GATE	61
11.3	SETTING THE BAND BRAKE ON THE GEAR BOX	61
11.4	SETTING THE BREAK LEVER TO VENTILIZE THE PE-PIPE	62
11.5	SETTING OF THE THREADED ROD	62
11.6	INSPECTION OF THE BAND BRAKE FOR RELEASE OF THE BAND BRAKE	63
11.7	SETTING THE GEARBOX SHUT-OFF	63
11.8	INSPECTION OF THE SHUT-OFF	64
12	SETTING TURBINE BRAKE	65
13	STATIV	65
14	OPTIONAL EQUIPMENT	66
14.1	OVERPRESSURE SHUT-OFF VALVE (OPTIONAL ON ECOSTAR)	66
14.2	LOW PRESSURE-SHUT OFF VALVE	66
14.3	COMBINED SHUT-OFF	67
15	WINTERIZATION – DRAINING	67
16	SERVICE AND MAINTENANCE	68
16.1	INSTRUCTION FOR LUBRICATING THE REEL SEAL	68
17	TECHNICAL DATA	69
17.1	STANDARD TYRES CART RAINSTAR T.....	70
18	TROUBLE SHOOTING.....	71
19	CONFORMITY CERTIFICATE	72

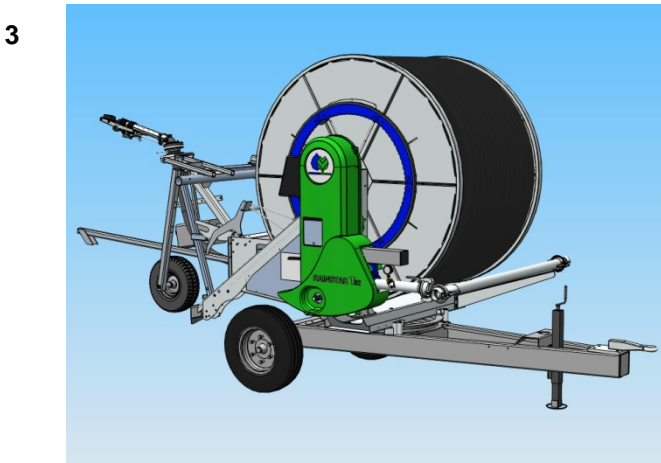

9

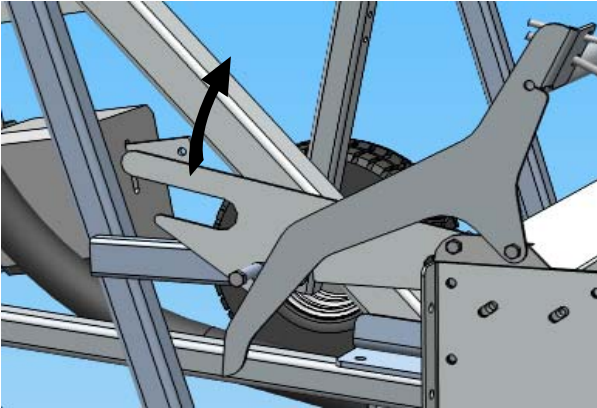

10

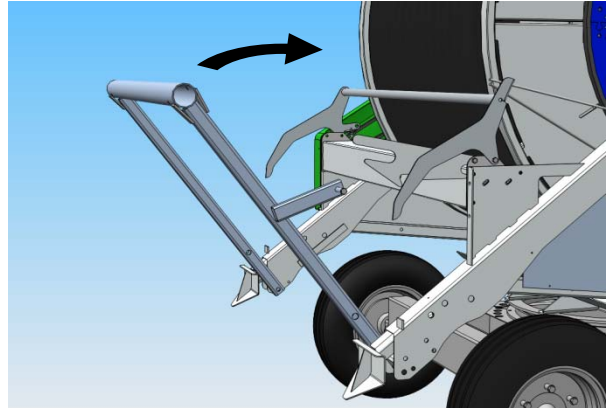

11



12



13

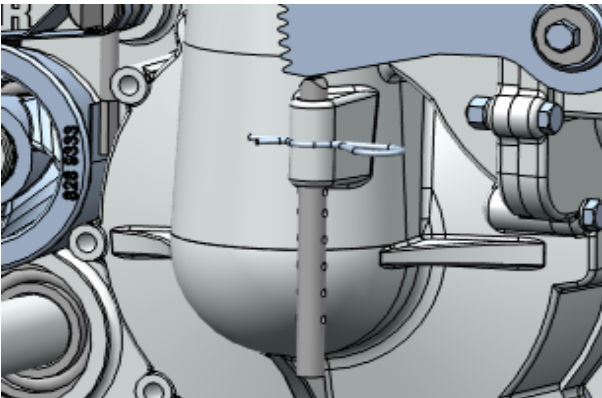

14

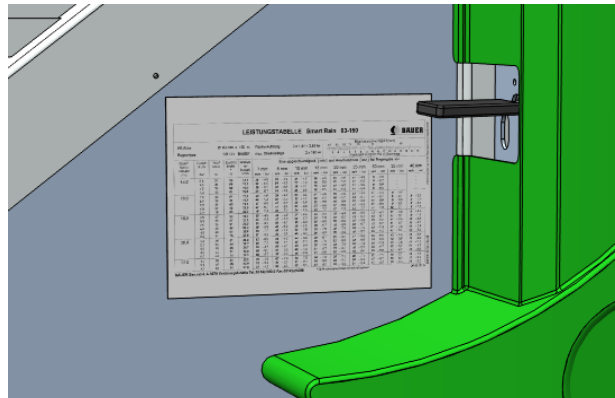

1 GENERAL INSTRUCTIONS

CE SYMBOL



The **CE symbol** that has to be affixed on the machine by the manufacturer outwardly demonstrates compliance of the machine with the directives for machines and other relevant EU directives.

EU conformity certificate (see Annex)



WARNING !

This "Warning" symbol refers to important safety instructions in this manual. Whenever you see this symbol be aware of possible injury hazards. Read the note following the symbol very carefully and inform the other operators accordingly.



CAUTION !

Non-observance of this instruction may damage or destroy the machine or individual components.

NOTE!

It is very important to observe this note or instruction carefully!

Qualified operators

These are persons who on behalf of their training, experience and instruction as well as their knowledge of relevant standards, rules, precautions to be taken for accident prevention, and prevailing operating conditions, have been authorised by the person in charge of plant safety to perform the respective tasks required, and in doing so are able to recognise and avoid potential hazards. Among other things, knowledge of first-aid procedures is also required.

Product liability

According to the product liability law every farmer is an entrepreneur!

According to §9 PHG (Product Liability Law), liability for damage to corporeal things caused by defective products is expressly excluded. This exclusion of liability also applies to parts not manufactured by **BAUER** itself but purchased from external suppliers.

Duty to furnish information

Even if he passes on the machine to a new owner later-on, the customer is obliged to hand on the operating manual to the new owner, too. The receiver of the machine must be instructed with reference to the mentioned regulations.

Intended use

- BAUER RAINSTAR T has been constructed exclusively for use in normal irrigation (intended use).
- Any employment beyond this normal use is considered non-conforming. The manufacturer is not liable for damage resulting from such non-conforming use, the sole liability for damage from non-conforming use is with the user.
- Intended use also includes compliance with manufacturer's operating, maintenance and service instructions.
- BAUER RAINSTAR T may be used and operated only by persons who are familiar with the system and aware of the hazards involved.
- All relevant rules for accident prevention as well as any other generally accepted specifications and regulations relating to safety, work medicine and traffic law must be strictly observed.
- Unauthorised modifications on the machine release the manufacturer from liability for damage resulting therefrom.

2 GENERAL

BAUER products have been designed and manufactured carefully, subject to a system of continuous quality control. BAUER RAINSTAR models T32, T42 are turbine-driven machines designed for fully mechanised and labour-saving irrigation. System set-up, repositioning, and operation are all done with the tractor, handling required by the operator is restricted to only a few manipulations.

BAUER RAINSTAR is a universal machine capable of covering fields of varying lengths and widths. There is no need for supervision while the system is operating.

Strict observance of all operating and service instructions in this manual is the basic prerequisite for many years of trouble-free operation. Therefore please make sure that all operators on your staff are familiar with the instructions given in this manual.

The model number as well as the serial number are stamped into the nameplate. In addition, the serial number is stamped into the frame of the undercarriage. Please state these data in all your inquiries, correspondence, warranty matters and parts orders.

We warrant for this RAINSTAR according to our General Terms of Sale.

3 SAFETY

For safety in general and in view of accident prevention the following points must be strictly observed.

General instructions

1. Read this manual before you put the system into operation and strictly adhere to all safety and operating instructions.
2. Acquaint yourself with all controls and functions of the machine before you start to work with it. It's too late when the system is already running!
3. The warning and indication stickers on the machine give very important instructions for safe operation. Observing them is essential to your own personal safety! If stickers are missing they have to be replaced.
4. Never put the machine into operation unless all guards and safety devices are completely mounted in their proper working position!
5. Do not handle the PE-pipe near the machine or the machine itself during pull-off and retraction .
6. Never set or service any part while the system is running (except for speed adjustments).
7. Keep a safe distance from the sprinkler while it is operating.
8. Ensure that the sprinkler's water jet does not hit public roads (accident hazard).
9. Keep a safe operating distance from electric power lines (depending on nozzle size and water jet). Consult your local power supply company regarding safe distances that have to be allowed.
10. When transporting (repositioning) the RAINSTAR – especially when a boom cart is involved - make sure that the safety distance from electrical power lines is strictly observed (height of machine, clearance of power line).
11. When you transport the RAINSTAR on public roads always observe the applicable traffic regulations (max. speed, max. transport width, reflectors etc.)
12. When you transport the RAINSTAR or load it on a trailer, always take into account that remaining water in the PE-pipe shifts the machine's centre of gravity upward. Be careful in curves and on sloping terrain!
13. Always ensure that locks and stops are secured according to the machine's general conditions of transport.
14. Maximum permissible speed: 10 km/h .

Power take-off

1. Drive-shaft protection tube and cone as well as the PTO guard – also on the machine side - must be mounted and in proper working order!
2. Never connect or disconnect the PTO drive shaft while PTO is running: The engine must be turned off, and the ignition key pulled out!
3. Attach the safety chain to keep the guard from rotating with the shaft!
4. Before you turn on the PTO make sure that the selected tractor PTO speed corresponds with the permissible implement speed! **Maximum 150 r.p.m.**
5. Before starting the PTO make sure that nobody is standing in the danger zone of the machine!
6. When drive shaft has been removed put the guard on the PTO shaft!

Hydraulic system (RAINSTAR T option)

1. When coupling the hydraulic hoses with the tractor's hydraulic system make sure that the entire hydraulic system is pressureless both on the tractor and implement side !
2. Inspect the hydraulic lines at regular intervals and replace them immediately in case of defects or ageing. Replacement hoses must comply with machine manufacturer's technical specifications!
3. Liquids emerging under high pressure (hydraulic oil) may penetrate the skin and cause serious injuries! An injured person must see a doctor immediately! Danger of infection!
4. Always depressurise the system before you work on the hydraulic system !

Maintenance

1. Never service or repair the machine unless the drive is turned off !
2. Dispose of oil, grease and filters according to local laws and regulations!
3. Before electric welding on the RAINSTAR, always uncouple the tractor and disconnect ECOSTAR battery!
4. Spare parts must meet manufacturer's minimum technical specifications! This is the case with original spare parts!

Safety distances Z from electric lines at:

IRrigation = ZR e. g.: with drinking water, ground water (e. g. well)
or running water (e.g. stream)

SlurryG = ZG e.g.: with liquid manure or slurry

H = minimum distance between sprinkler upper edge and conductor cable
When crossing beneath an electric line

The safety distance, when crossing an electric line, is reached, if the distances per the below chart are kept. The water beam may touch the conductor cable, but may not be higher than the conductor cable.

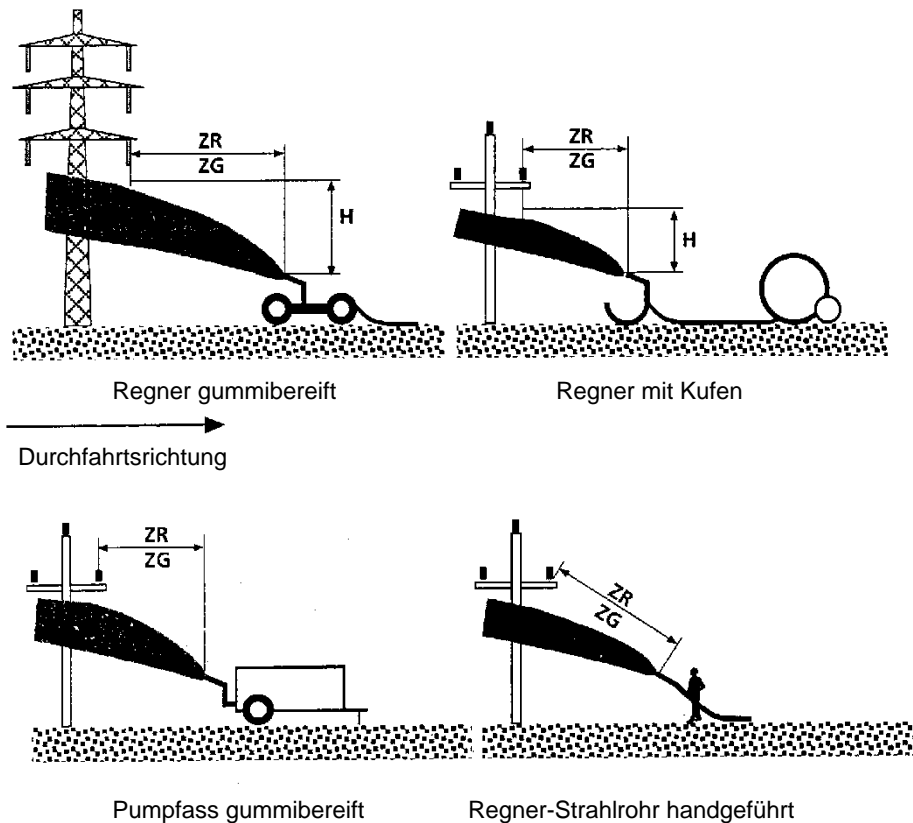

WARNING: Do not spray slurry on insulators and poles !

Type and operation mode of the sprinkler		Safety distance Z in m, measured on the ground							
		With rubber wheels or directed by hand With metal or synthetic pipes				With skids or stationary/fixe With metal cart and metal pipes			
		Nozzle diameter in mm or. Flow in m ³ /h							
		Jet type		26 mm \triangleq 50 m ³ /h		36 mm \triangleq 100 m ³ /h		26 mm \triangleq 50 m ³ /h	
		Spray	Full	Spray	Full	Spray	Full	Spray	Full
Up to 1.000 V H = 1 m	ZR	1	5	1	5	1	5	1	5
	ZG	1	8	1	8	1	8	1	8
Up to 30.000 V H = 2,5 m	ZR	3	9	5	21	3	7	4	9
	ZG	5	11	7	23	5	9	6	11
Up to 110.000 V H = 3 m	ZR	3	12	5	24	3	9	4	15
	ZG	5	14	7	26	5	11	6	17
Up to 220.000 V H = 4 m	ZR	4	14	6	26	4	12	6	22
	ZG	6	16	8	28	6	14	8	24
Up to 380.000 V H = 5 m	ZR	5	16	7	26	5	14	6	22
	ZG	7	18	9	28	7	16	8	24

The indicated safety distances in the above chart are valid for a nozzle diameter of 26 mm or 36 mm at an operating pressure of 5 bar. **For higher operating pressures the safety distances have to be increased by 2 m.** The safety distances are not valid when normed jet pipes, like they are used by fire brigades, are being used.











When applying polluted water or slurry, note that a conductive layer can build up on the insulators. **Therefore do not spray on the insulators.!** Flashovers and insulator damage can otherwise cause power failure.

If metal sprinkler pipes are laid parallel to a high voltage power line, this can lead, even without irrigating, to a perceptible contact voltage because of the electric influence. Touching the pipes is not dangerous, but can be unpleasant and painful. This is why it should be avoided to lay metal pipes parallel to high voltage lines or only over the shortest distances possible. When using synthetic pipes, you will not encounter any of these problems.

NOTE ! DO NOT PUT PIPE LINE PIECES INTO A VERTICAL POSITION IN THE RANGE OF HIGH VOLTAGE LINES !

4 WARNING SYMBOLS

Danger points on the RAINSTAR are specifically marked by safety stickers. These stickers must be affixed to the mentioned points clearly visible. They serve to protect persons working on or near the system.

- | | | |
|----|---|--|
| 1. |  |  <p>WARNING !</p> <p>Study and observe the manual and all safety instructions carefully before you put the system into operation.</p> |
| 2. |  |  <p>WARNING !</p> <p>Before any service and repair work, always stop the machine and read the operating manual</p> |
| 3. |  |  <p>WARNING !</p> <ol style="list-style-type: none"> 1. The operating range of the RAINSTAR must always be at a safe distance from electric power lines. 2. This applies to both wide-range sprinklers and machines operating with boom cart AS 26/32.
The water jet of spray nozzles and sprinklers must not reach electric power lines. |
| 4. |  |  <p>WARNING !</p> <p>Never remove safety covers while system is operating.
Make sure that the RAINSTAR's reel does not move during repairs. Slacken the PE-pipe.</p> |
| 5. |  |  <p>WARNING !</p> <p>Keep away from the rear of the RAINSTAR!!
Danger of bruising by the incoming sprinkler cart. Keep your distance!</p> |

5 DESCRIPTION

The RAINSTAR is a universal irrigation machine designed and constructed for labour-saving irrigation of varying lengths and widths of fields with the greatest variety of crops.

The main components of the machine are: a two-wheel undercarriage with the turntable on which the pipe reel can be swivelled through 270° into the irrigation lane; special PE-pipe, drive system with TVR 18 full-flow turbine as well as the four-stage compact gearbox, and a sprinkler cart with the BAUER wide-range sprinkler

The special composition of materials of the PE-pipe (polyethylene) has been purpose-designed for the RAINSTAR's range of applications.

TVR 20, the heart of the system is a full-flow turbine mounted in a flow-promoting position directly on the reel inlet and driven by the irrigation water. Maximum efficiency rating guarantees minimum pressure loss.

Power is transmitted from the turbine onto the reel over a 4-stage gearbox and a chain drive.

A band brake on the gearbox ensures that the reel neither turns back in the shut-off position nor continues to turn after the pipe pull-off. This way the PE-pipe windings do not slacken on the reel.

The retraction speed of the sprinkler cart with the sprinkler is infinitely variable.

Speed is adjusted with the electronic control unit ECOSTAR 4300.

The 4-line display indicates the momentary system operating mode. (See chapter on ECOSTAR) A mechanical speed control option is also available.

Never exceed maximum permissible connection pressure of 11 bar!

If needed, it is possible to interrupt system operation completely with the gear-shift lever. This also serves as emergency stop. The PE-pipe is braked and remains stretched. Before you restart the system you must slacken the PE-pipe.

	WARNING! Remove drive protection only after water inlet to the machine has been closed and the stretched PE-pipe released.
---	---

To slacken a stretched PE-pipe, push the gear-shift lever down carefully (see proper procedure).

The mechanical pipe reeling device ensures trouble-free winding of the PE-pipe on all layers.

ECOSTAR 4300, the electronic speed control system, maintains the retraction speed constant on all levels independent of the length of the laid down PE-pipe length.

It is also possible to mount ECOSTAR 4200 as an option, which offers further applications and supplementary information.

Shut-off

At the end of the irrigation strip the cart is automatically lifted into the transport position. Thereby the automatic drive shut-off is activated by a system of rods. After the shut-off the raised cart is locked in the transport position by the transport guard. If the machine is equipped with a an electric shut-off valve (with ECOSTAR) or a hydraulic shut-off valve (mechanical speed regulation), water supply to the machine is closed simultaneously. After shut-off the RAINSTAR can be transported to its next setting-up position immediately. The PE-pipe can be pulled off or laid down again, the water supply opened, and the machine is ready for the next run.

Transport

When driving on public roads the reel must be turned into the driving direction and locked in position with the lock bolt to keep it from swiveling. The PE-pipe must be fully wound up on the reel and the cart lifted and locked and the transport guard engaged. The jack and both rear machine supports must be withdrawn to their uppermost position. The support legs must be secured with lock pins.

Safe for an official permit, 10 km/h is the maximum permissible driving speed. For increased safety against overturning we recommend to set the RAINSTAR wheels at the maximum possible track width. Keep in mind that water in the PE-pipe increases the system weight considerably and shifts the centre of gravity upward.

It is possible to transport the machine between hydrants in the field with the cart lifted on the side. In this configuration the driving speed must always be adjusted to the existing conditions and should never exceed 5 km/h. Please note also that this type of transport requires a wider driving lane.

6 PUTTING INTO OPERATION

ASSEMBLY INSTRUCTIONS

In order to provide optimum conditions for transport and time-saving assembly, all components are directly mounted or fixed on the machine.

The shipment contains no loose or separate parts.

Please assemble the RAINSTAR according to the following instruction before the initial start-up. This takes about two hours.



WARNING !

PERFORM ALL STEPS WITH UTMOST CARE IN ORDER TO AVOID ACCIDENTS AND INJURIES.

If you use a truck mounted crane to unload the RAINSTAR, please proceed as follows

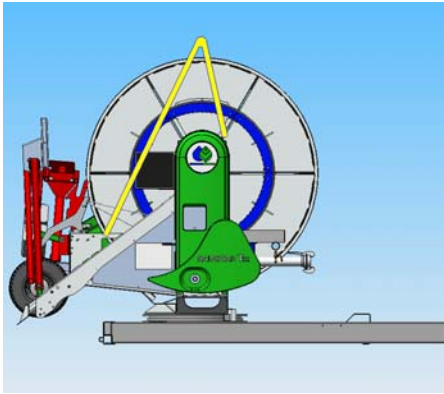

- 1.1. Pick up the machine with the crane hook.
Lower it in horizontal position to about 0.5 m above the ground

- 1.2. Mount the RAINSTAR wheels. The threaded hole on the axle (for indication bolt) must point towards the setting slot.

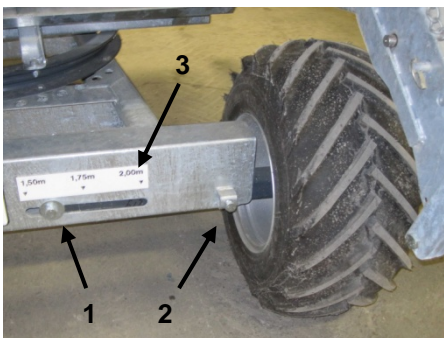

- 1.3. Set the desired RAINSTAR track width and fix it.
Track width indication (point 3),
securing (points 1+ 2).

- 1.4. Fix the axle with bolts 1+2
- 1.5. Mount the jack.
- 1.6. Park the RAINSTAR on the ground on its wheels and on the jack

2 If you use a FORKLIFT to unload the RAINSTAR from the truck, proceed as follows:

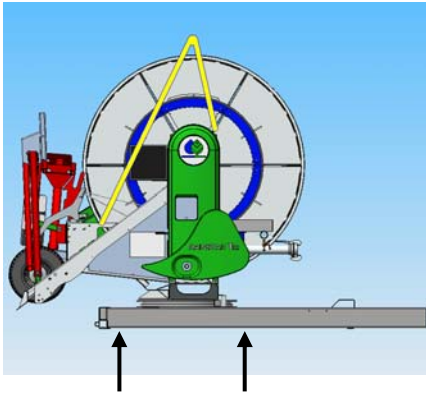

- 2.1. Forklift hoisting position in the middle of the reel. Lower the machine in horizontal position.
 - 2.2. Put down the machine on three wooden blocks, one below the drawbar and two below the frame at the axle positions. Ensure that the assembly is firmly support !
 - 2.3. Pull out the turntable lock bolt and turn the reel 180 degrees.
 - 2.4. Secure the turntable again with the lock bolt to prevent swivel motion. The drawbar is opposite the cart now.
 - 2.5. Insert the axles in the chassis frame. Adjust track width as needed. The threaded hole for the indication bolt must point towards the setting slot. (See point 1.3).
 - 2.6. Secure the axles with the bolts. (See points 1.4.-1.5.)
 - 2.7. Mount the jack (see point 1.6).
 - 2.8. Lift up the RAINSTAR with the forklift on the rear (on the cart side) and remove the wooden blocks below the axles.
 - 2.9. Lift up the drawbar with the jack or with the forklift and remove the wooden block underneath the drawbar
3. Mounting the drawbar coupling ring

Mount the coupling ring depending on the tractor's coupling height. In coupled position the RAINSTAR should be standing about horizontal.

Note: Tighten the bolts with 210 Nm!

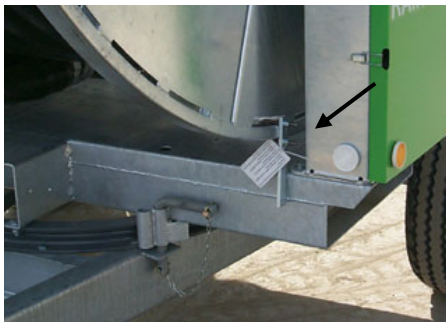

4. Remove the locking bracket from the reel

5. Remove the tape from the gear shift lever.
The gear shift lever remains in the same position.

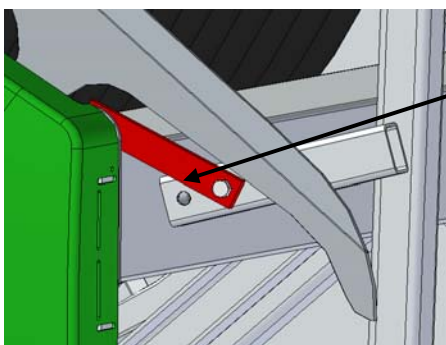

6. Remove the locking bracket from the cart lifting frame

RAINSTAR T32, T42



7. Fix the hand wheel to the shaft with the too thing and release the PE pipe about 40cm by rotating the hand wheel.

OPTION

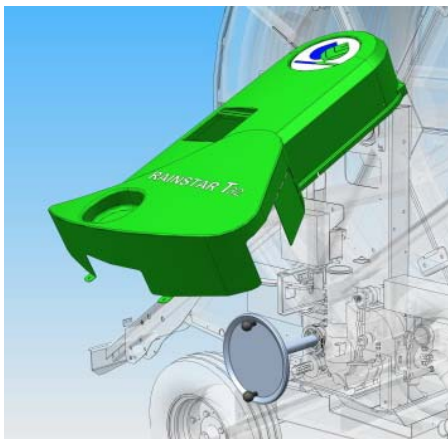
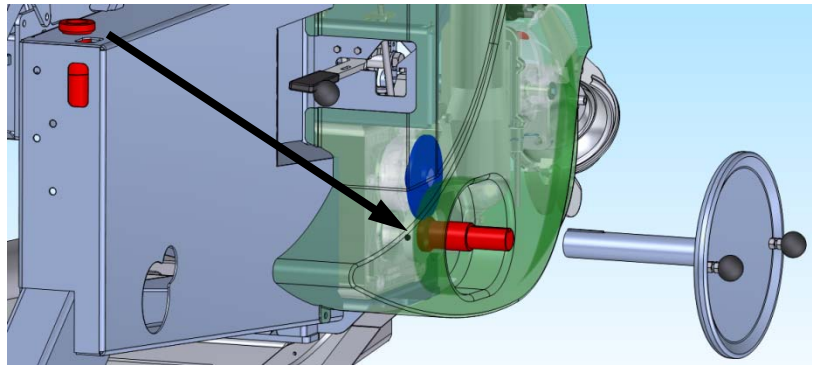

Standard reeling with reduced transmission via hand wheel

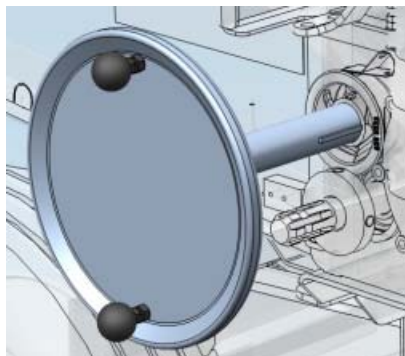

- 8 Pull back the cart (lifting frame) by hand until the pipe is stretched (approx. 50 cm). The cart is suspended about half way down.

Mount the shut-off rod s on the cart-lifting frame



Caution: Test the shut off functions ! Malfunctions can cause damages on the machine ! (see operating manual)

9. Symmetric Cart



Turn the sprinkler connection with the pendulum 90 degrees into operating position.

Caution: The bend on the sprinkler connection pipe has to be on the top of the pendulum).



- Mount the sprinkler on the cart.

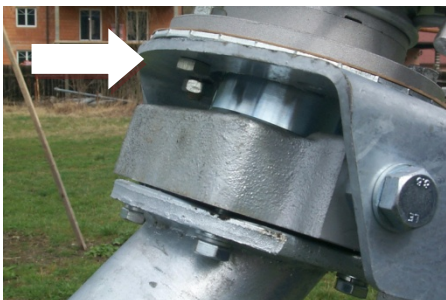

- Attention: when installing the sprinkler mount the screw bottom-up



- Place the weights on the pendulum.

10. Asymmetric Cart

- Mount the asymmetric sprinkler connection with the pendulum and balancing weights in the operating position. In doing so the sprinkler's position is about in the middle of the cart.
- Two balancing weights remain on the pendulum. Depending on the nozzle size, mount none, one or two balancing weights on the wheel base opposite the PE-pipe.
- Mount the sprinkler on the cart.



- . Mount the asymmetric sprinkler connection with the pendulum and balancing weights in the operating position. In doing so the sprinkler's position is about in the middle of the cart.
- Two balancing weights remain on the pendulum. Depending on the nozzle size, mount none, one or two balancing weights on the wheel base opposite the PE-pipe.

11. Close the turbine drain valve.
13. Connect the ECOSTAR battery
The key for the lockable door of the ECOSTAR is in the container with the operating manual
14. Test the mechanical machine shut-off system as described in the operating manual

All bearings of the RAINSTAR are greased before they leave the factory. Yet, before putting the machine into operation grease all parts as described under section 14 "Service and Maintenance". Also check screws in terms of their torque, tire pressure, etc. Find the corresponding information in the same section

6.1 PREPARATIONS FOR THE RUN

Pict.
no.

- 1 Set the specific sprinkler-cart track width required for the crop and fix it.
Symmetric cart, maximum track width 1500 – 3000 mm
Asymmetric cart, maximum track width 1500 – 2000 mm
- 2 Place the number of balancing weights required on the sprinkler pendulum

Symmetric wheel cart		
Nozzle sizes	track width 1500	
14 - 24 mm	2 weights	
> 24 mm	3 weights	
Asymmetric wheel cart		
Nozzles sizes	Weights on pendulum	Weights on wheel base
14 - 22 mm	2	0
22-26 mm	2	1
>26 mm	2	2

If the cart is used in asymmetric configuration, 2 weights must be placed on the sprinkler pendulum and one or two weights on the opposite cart wheel (see chart). Moreover, a second cart hook must be used.

Set the part circle on the wide-range sprinkler (approx. 220° for full strip width). For more details see separate sprinkler manual.

6.2 MACHINE TRANSPORT TO SETTING-UP POSITION

- 3 To prepare the machine for transport, turn the reel into the driving direction and secure it with the lock pin. Cart, jack, and both rear support legs are raised.
For lateral PE-pipe pull-off position the RAINSTAR on the border of the field in such a manner that the end of the PE-pipe lies in the middle of the irrigation strip between two crop rows.
Park the machine and uncouple it from the tractor.

6.3 OPERATING MODE I: PE-PIPE PULL-OFF

6.3.1 MACHINE SET-UP

- 4 Adjust the parked machine with the jack in as level a position as possible.
- 5 For lateral PE-pipe pull-off, remove the lock pin, turn the reel into the irrigation lane, and secure it again with the lock pin.
For straight PE-pipe retraction the pipe reel must point exactly into the direction of the irrigation lane.
- 6 Pull out the bolts of the machine-support transport guards.



WARNING!

When the bolts are removed the machine supports slide to the ground automatically.

- 7 Drive the supports into the ground by means of the detachable hand wheel.
- 8 Secure the bolts with pins.



WARNING

Make sure that the RAINSTAR stands firmly and cannot alter its position during the run.



WARNING!

If the supports do not dig into the ground sufficiently on hard soil in spite of the sharp shields, holes must be provided in the soil into which the supports are lowered, in order to guarantee sufficient machine stability.

6.3.2 LOWERING THE CART

Positions of the gear shift lever

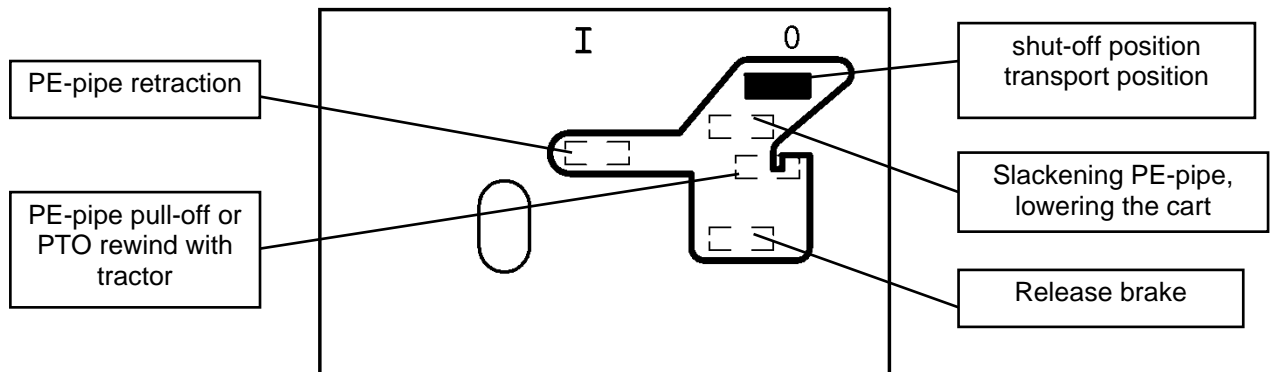

- 9 Disengage the mechanical lock of the cart. Push locking hook up.

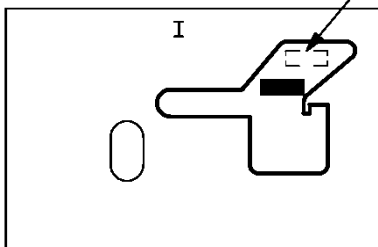

Push the gear shift lever down carefully – the cart moves down slowly



WARNING!

The operator's position must be outside the cart lowering area

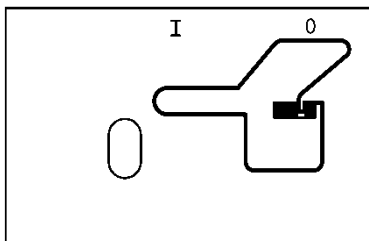

Move the gear-shift lever to the „PE-pipe pull-off“ position. Push the lever down and let it click into place.

6.3.3 CHECKING THE SHUT-OFF

CAUTION !	Check if the final shut-off works properly before the first start-up and at the beginning of every season.
------------------	---

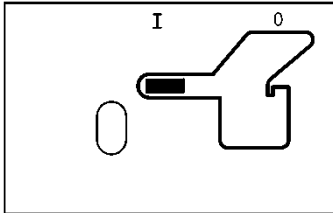

Before you put the machine into operation (turbine idle) with the cart lowered and at least 1 meter of PE-pipe pulled off: move the gear shift lever to “PE-pipe retraction”.



Help when changing gear
Reset the brake wheel with a screw driver.

- 10** Operate the shut-off frame on the retraction side of the RAINSTAR manually until system shut-off is activated.
Thereby the gear shift lever must be shifted from the operating position and jump into position “0”. If this is not the case, the shut-off system needs adjustment. See separate section in this manual for setting instructions.

6.3.4 PE-PIPE PULL-OFF

- 11** Pick up the draw-out hook with the toolbar and pull off the pipe with the cart.
- 13** Symmetric or asymmetric wheel cart need not be lifted for pull-off.
Maximum pull-off speed: do not exceed 5 km/h!

CAUTION !	Do not stop the pull-off abruptly. Always slow down gradually for intermediate stops in the field or at the end of the pull-off. Stop pipe pull-off when the white marking line becomes visible on the reel – the end of the pipe is reached.
------------------	--

CAUTION !	If the PE-pipe has been exposed to the sun for a longer time or if its surface temperature rises above 35 °C for some other reason, you must let water run through the pipe for several minutes to cool it off before pull-off or retraction.
------------------	--

6.4 OPERATING MODE II: LAYING DOWN THE PE-PIPE

Another method of putting down the PE-pipe on the ground is to unreel it while the machine is travelling over the field. This method is mostly used when heavy soil makes it impossible to pull the cart across the field, or when the field length is more than once or twice the PE-pipe length. Moreover, this laying down method can be done with smaller tractors because no pulling forces are applied on the pipe.

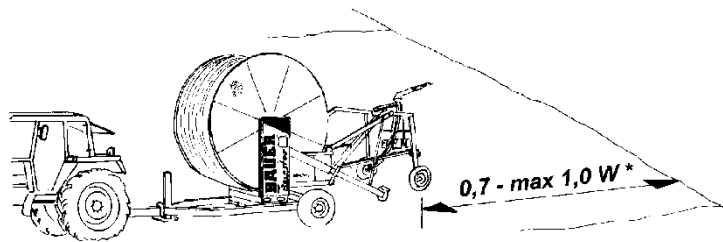

Drive the RAINSTAR into the field allowing for the sprinkler's distance of throw.

*) W = distance of throw

Lower the cart as described under operating mode I, "Lowering the cart" and slightly anchor it. Now drive across the field with the RAINSTAR.

Carry out all other steps as described above.

Pipe guide (option)

It is possible to mount a pipe guide option which ensures that the PE-pipe is not laid down in a wavy line due to the reel width. With this pipe guide the PE-pipe is laid down in a straight line according to the crop rows.

6.5 SETTING OF TURBINE REGULATION

13

Q m ³ /h	sichtbar (Loch)
13 - 20	5
20 - 25	4,5
25 - 30	4
30 - 40	4
40 - 50	3
> 50	2

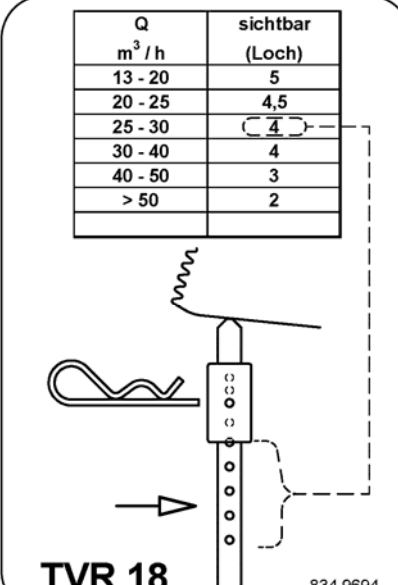

TVR 18 834 9694

NOTE!

Depending on the RAINSTAR's flow-rate, the operating range of the turbine regulation must be limited before start-up. Adjust the setting bolt on the turbine which limits the toothed segment of the regulation according to the chart on the opposite.

A wrong setting may block the turbine regulation!

The flow rate can be found in the perfor

6.6 STARTING PE-PIPE RETRACTION

Couple the pressure hose. Open water supply.

Determine the required retraction speed in the performance chart, depending on nozzle size and precipitation rate.

The performance start decal is placed on every machine.

Select the speed setting according to the following table.

1	8	---	25	m / h
2	20	---	42	m / h
3	28	---	60	m / h
4	> 48			m / h

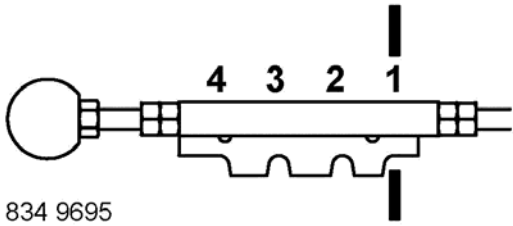

834 9695

Note !

Correct gear transmission guarantees economical and fail-safe performance!.

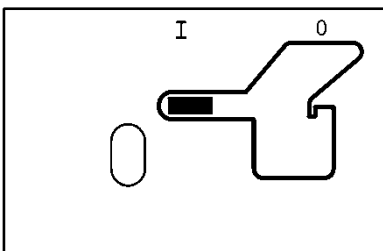

As soon as the operating pressure is reached and water is ejected from the wide-range sprinkler in a full jet without air bubbles, switch gear shift lever to "PE-pipe retraction". Retraction starts



Set the required retraction speed with the keys in the operating mode of the ECOSTAR 4300.

The retraction speed can be changed any time, also while the machine is operating
See "Retraction speed control with ECOSTAR"

6.7 RETRACTION STOP, RESTART (EMERGENCY SHUT-OFF)

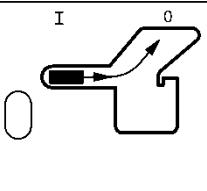
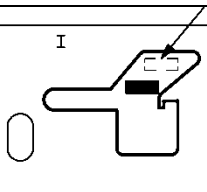
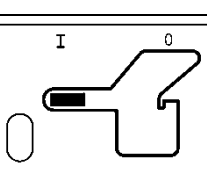
	<p>You can stop PE-pipe retraction by hand during system operation. For this purpose you push the gear shift lever from the operating position with your open hand (do not hold the lever tight). The lever jumps into "0" position, the reel is braked and the PE-pipe remains stretched</p>
	<p>Before a restart the PE-pipe must be slackened. For this purpose you push the gear shift lever down carefully until the pipe reel turns back slowly and the pipe slackens. Make sure that no loose windings build up on the reel</p>
	<p>To restart the system, push the gear shift lever into the operating position again and PE-pipe retraction starts again.</p>

6.8 PTO REWIND:

If necessary, the PE-pipe can be wound up with the tractor and a PTO drive shaft. For this purpose you move the gear shift lever to the "pull-off/ PTO rewind" position. In this position the band brake is released. This gear shift lever position is also used for PE-pipe pull-off.

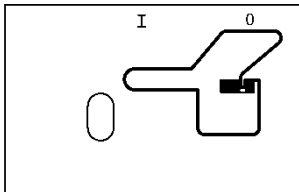

PTO rewind is needed when irrigation with the machine no longer needs to be continued due to natural rainfall or if the PE-pipe has been pulled off for draining before winterization

 <p>Warning!</p>	<ul style="list-style-type: none"> • Retract the pipe at the lowest possible PTO speed - start slowly and smoothly and avoid jerks. • Maximum PTO speed = 150 r.p.m. • Operate with minimum drive shaft bending angles in order to avoid excessive stresses. • If the PE-pipe is covered with mud it should be loosened and lifted from the ground to reduce the tensile forces. • If the soil is deep and heavy, PE-pipe rewind must be slower in order that the permissible loads on PE-pipe and RAINSTAR are not exceeded. • If you disengage the tractor's PTO shaft during PE-pipe rewind, make sure that the pipe reel stands still when you re-engage the PTO shaft. Double motion can severely damage the equipment!
--	---

<p>NOTE !!</p>	<p>During PTO rewind the automatic final shut-off system is inactive. Therefore you must stop the PTO shaft in time and wind up the last piece of PE-pipe with the hand wheel. This way you prevent damage to cart, shut-off system, gearbox, etc</p>
-----------------------	---

7 ECOSTAR 4300

RETRACTION SPEED CONTROL

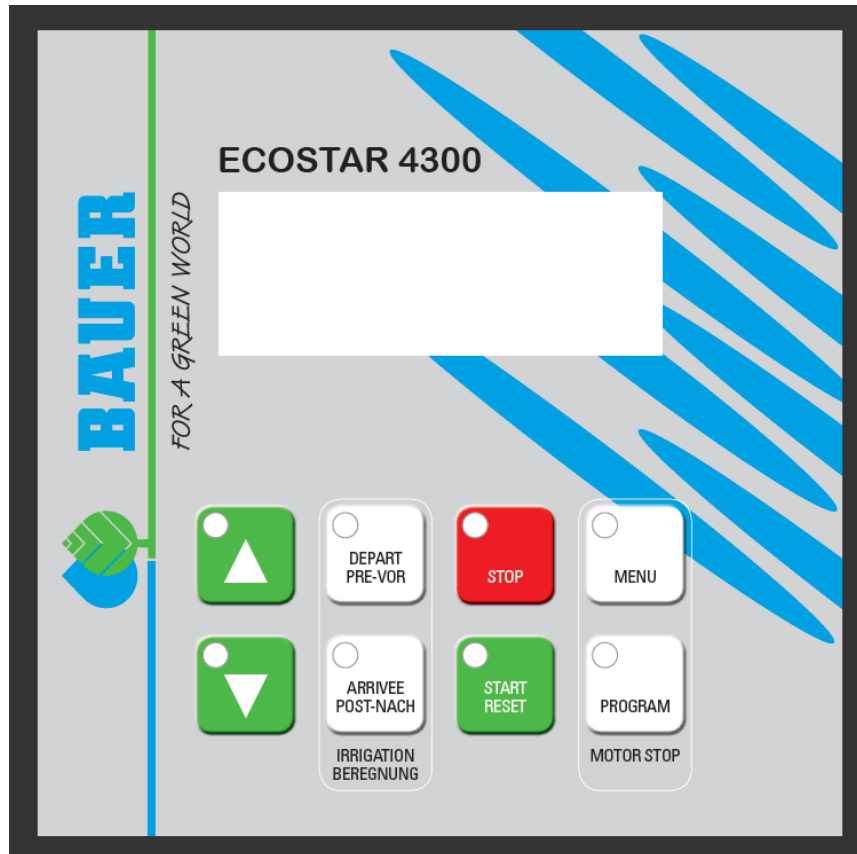

7.1 GENERAL

The **BAUER ECOSTAR 4300** allows you to operate your irrigation machine with ease at the touch of a button.

An illuminated four-line display offers you comprehensive indication of the machine's current operational status.

Through permanent comparison of set-point and actual value of the retraction speed you can administer the precipitation rate you need.

The *ECOSTAR 4300* consists of the electronic box, a cable harness with the connected sensors for the PE- pipe length retraction speed and shut-off as well as connections for battery, solar panel and the turbine regulation motor.

Connections are also provided for installing a pressure switch and an electric shut-off valve (both optional).

The electronic system of the *ECOSTAR 4300* is rigidly built and has been tested under different climatic conditions. If problems still occur it is advisable to exchange the complete electronic box. If a sensor is defective it is possible to exchange only the sensor, too.

7.2 DISPLAY WINDOWS AND MENU OVERVIEW

SPEED		30.0m/h	
DOSE	22 mm		
TIME	14:10	STOP	7:43
STATUS	Operation		

Standard display

ZONE		1	30.0m/h
DOSE	22 mm		
TIME	14:10	STOP	7:43
STATUS	Operation		

Standard display, Zone active

DISTANCE	123M
BATTERY	12.8V
CHARGE ON	0.231A
PRE-	0:45 NACH-
	0:45

Press button **MENU** one time, in order to get to the display of menu 2.

PRESSURE SENSOR	■
STOP SENSOR	■
SPEED SENSOR	■ ■
MOT1	0.0A MOT2
	1.8A

Press button **MENU** two times, in order to get the display of menu 3.

ACT. SPEED	22M/H
START	0:00
OPERATING HOURS	123h

Press button **MENU** three times, in order to get to display of menu 4.

0m	30.0m/h	0m
0m	30.0m/h	0m
0m	30.0m/h	0m
0m	30.0m/h	0m

Press button **MENU** four times, in order to get to display of menu 5.

SIGNAL	23
NETWORK HOME	
A:	+45123456
B:	+45234567

Press the button **MENU** five times, in order to get to display of menu 6.
(Only if GSM has been selected)

When the sign ■ appears on the display, it means that the respective function is turned on.

STANDARD MENU:

SPEED	30.0m/h		
DOSE	22 mm		
TIME	14:10	STOP	7:43
STATUS	operation		

Standard display

SPEED

Speed can be changed at any time during the irrigation, using the keys „+“ und „-“.

ZONE

Current Zone 1 – 4, with corresponding speed. The speed cannot be changed. (zone active)

DOSE

The precipitation rate is calculated by means of constants, and shows the current mm for irrigation. If the **SPEED** increases, the **DOSE** decreases. (constant 11 and 12)

TIME

To set the time: first set the speed to 11,1 m/h, and then press the **PROG-** button 3 times to get to **<CONST 1 TIME>**. The time can be set with the buttons „+“ and „-“. When the battery has been removed the time is 00:00, and remains zero until it is set.

STOP

Time when the irrigation is finished incl. pre- and post irrigation.

STATUS

Irrigation status:
<Stop sensor >
<Running >
<PRE Irrigate >
<POST Irrigate>
<LOW Pressure >

Explanation see STATUS chapter

If the display shows **LOW BATTERY** instead of **SPEED**, the voltage in the battery is less than 11,8 V and the battery needs to be charged.

MENU 2

DISTANCE	123M
BATTERY	12.8V
CHARGE ON	0.231A
PRE-	0:45
POST-	0:45

DISTANCE

The remaining length of the pipe. Distance can be changed immediately after pressing **PROG** three times, then it can be changed with keys „+“ and „-“.

BATTERY

Battery voltage.

CHARGE ON

Shows if the battery is charged from the solar panel. The battery is charged when the voltage is below 14,0 volt.

PRE-

Current pre irrigation time.

POST-

Current post irrigation time.

Pre- and post irrigation time can be changed immediately after pressing **PRE-** or **POST-** with keys „+“ and „-“.

MENU 3

PRESS SENSOR	█
STOP SENSOR	█
SPEED SENSOR	█ █
MOT1 0.0A MOT2	1.8A

PRESS SENSOR

Shows if the pressure is high. The marker is on when the water pressure is high.

The machine can only work when the pressure is high.

STOP SENSOR

Shows if the stop switch is activated. The marker is on when the stop switch is on.

The machine can only work when the stop switch is on.

The stop switch has three functions:

- 1: Resets the distance counter
- 2: Post-irrigation
- 3: Inhibits the pulses to the regulating motor.

SPEED SENSOR

Test speed sensor. The marker is on when the magnets activate the speed sensor.

MOT1, MOT2

Shows the current power consumption of the motor. The motor is stopped when the power consumption exceeds 4,5 A. If the power consumption exceeds 4,5 A, and the motor has not reached its end position the shut off valve is blocked.

MENU 4

ACTUAL SPEED	22M/H
START	0:00
WORKING HOURS	123h

ACTUAL SPEED

Shows the current speed of the machine. Furthermore, the maximum running speed of the machine can be checked if the *ECOSTAR 4300* is set to a much higher speed than the machine can run.

The current speed can differ from the set speed, especially at the start. This is not an error because the *ECOSTAR 4300* ensures that the medium speed over a distance of 10 m is correct.

START

With this function the starting time of the machine can be delayed for up to 24 hours.

To set the start time press „PROG“-key three times and the time can be set with the keys „+“ and „-“.

WORKING HOURS

The total working hour since the electronic was started for the first time.

MENU 5

0m	30.0m/h	0m
0m	30.0m/h	0m
0m	30.0m/h	0m
0m	30.0m/h	0m

In this menu the irrigation can be set and four different retraction speeds are possible. Press the „PROG“ key three times. Further details see below.

MENU 6

SIGNAL	23
NETWORK	HOME
A:	+45123456
B:	+45234567

SIGNAL GSM-signal strength
 NETWORK GSM-Network type
 A: First phone number on the SMS-list
 B: Second phone number on the SMS-list.

Detailed description in the chapter GSM.

START:

The turbine can only start if the magnet activates the stop sensor (or stop sensors), see Menu 3 for controlling the function of the stop sensor. When the „**START**“ key is pressed the shut-off valve opens. Next the by-pass valve closes (the turbine starts). If the magnet does not activate the stop sensor only the shut-off valve opens. This is used if the pressure should be released before disconnecting the hose at the hydrant.

DELAYED START TIME OF IRRIGATION:

First press „**STOP**“-key for closing the inlet of water. Next press „**MENU**“-key 3 times (Menu 4), „**PROG**“-key 3 times and you can start time. Finally, pre- and post- irrigation can be selected.

STOP:

When the magnet is removed from the stop sensor, the turbine stops and the shut-off valve over-pressure closes (or if available the shut-off valve low-pressure opens).

If post-irrigation is chosen, the turbine stops and after the post-irrigation time the shut-off valve closes. If the key „**STOP**“ is pressed, the turbine stops and the shut-off valve closes, regardless if post-irrigation was selected.

SUPERVISON:

The ECOSTAR 4300 has an integrated supervision system. SUPERVISON is activated if for some reason the machine irrigates at the same place longer than a specified time. This time is factory adjusted to 20 minutes, see programming for changing this time. If it set to 0 there is no supervision.

SPEED :

The speed is set with keys „+“ and „-“, at first the speed changes step by step 0,1 m/h, after 10 steps for 1,0 m/h. The speed can be changed at any time, even while the machine is running. If the time is checked it shows the new time for the remaining irrigation.

PRE-IRRIGATION:

Pressing the key **PRE-** can activate pre-irrigation. The time for pre-irrigation is calculated by the *ECOSTAR 4300* as 8 x the time for running 1 meter with the current speed.

The constant „8“ (constant no. 2) can be changed, see programming. If the pre-irrigation is on the machine starts and runs 1/2 pm enter and then it stops for the pre-irrigation time. By pressing the key „**START**“ the pre-irrigation is cancelled. The magnet at the stop sensor should be in place, before activating the pre-irrigation.

POST-IRRIGATION:

The post-irrigation can be activated by pressing the key „**POST-**“. The time for post-irrigation is calculated by the *ECOSTAR 4300* as 8 x the time for running 1 meter the current speed. The constant „8“ (constant no.3) can be changed, see programming. The post-irrigation starts to count down when the magnet is removed from the stop sensor. When the magnet is removed, the motor for speed regulation stops the turbine. After the post-irrigation time the shut-off valve closes (or opens, is available, the valve low pressure) At machines with only one motor for speed regulation the turbine starts after the post-irrigation. By pressing the key „**START**“ the post irrigation is cancelled. The magnet at the stop sensor should be in place before activating the post-irrigation. If the constant no.8 “early stop” is selected, this function is activated. The machine shuts down if the distance is reached.

7.3 PROGRAMMING OF 4 DIFFERENT SPEEDS

Display must show menu 5.

The pipe should be pulled out before programming, so the computer can calculate the distance of the field to be irrigated.

In the following example the length of the field to be irrigated is 400 m.

Press the „**PROG**“-Key 3 x. The display shows.

400m	30.0m/h	0m
0m	30.0m/h	0m
0m	30.0m/h	0m
0m	30.0m/h	0m

The desired speed can now be set, here 25,0 m/h. Then press the „**PROG**“-key 1 x. The display shows:

400m	25.0m/h	0m
0m	30.0m/h	0m
0m	30.0m/h	0m
0m	30.0m/h	0m

The desired distance can now be set, here 300 m. Then press the „**PROG**“-key 1 x. The display shows:

400m	25.0m/h	300m
300m	30.0m/h	0m
0m	30.0m/h	0m
0m	30.0m/h	0m

Now the first zone is programmed and the procedure is continued for all 4 zones.

Zone 4 automatically ends at 000m.

When zone 4 is programmed press again the „**PROG**“-key. The display shows:

DLETE MENU PRESS
SAVE PROG PRESS

By pressing the key „**PROG**“- the program is saved and the irrigation is carried out according to the program. By pressing the key „**MENU**“-the program is deleted and the speed stays the same for the whole field.

7.4 STATUS DISPLAY

STATUS:	Status messages in display
EMERGENCY:	machine has not been started, speed impulses, however, are being received and it is trying to maintain the speed requested.
RUNNING:	Machine is irrigating, everything is working properly.
LOW PRESSURE:	Water pressure is below pressure switch threshold. Machine acts depending on machine data.
START:	Operator has pressed „ START “-button and the start sequence is in progress
START REMOTE:	Machine is starting due to an SMS .
START DELAY :	Machine is waiting for start delay to elapse (see menu 4).
START PRESSURE :	Machine has started due to pressure rise. Machine uses pressure level to start 2 nd machine on string.
START DENIED:	Operator is holding „ STOP “-button to prevent PRESSURE- and REMOTE start zu verhindern.
STOP USER:	Machine has stopped due to operator STOP .
STOP REMOTE:	Machine has stopped due to an SMS .
STOP SENSOR:	Machine has reached end and is stopped by STOP SENSOR .
STOP DISTANCE:	Machine has reached distance for stop (see constant No. 8 for early stop).
STOP DELAY:	Machine has reached stop but waits nn seconds to proceed stop sequence..
STOP DENIED:	Operator is pressing „ START “-button to prevent REMOTE stop.
SUPERVISION TIME:	Machine has stopped due to supervision time is elapsed. Machine has not moved in nn minutes (see constant for supervision time)
FORCE LOW PRESSURE:	Machine opens shut-off valve to force pressure drop in order to stop the pump. After 2 minutes valve closes to prevent draining of pipe.
PRE IRRIGATION:	Machine is performing pre irrigation.
POST IRRIGATION:	Machine is performing post irrigation.

There are different constants that can be set by the user.

These constants will be saved for years even if the battery is disconnected.

7.5 THE MOST COMMON COMBINATION OF DIFFERENT CONSTANTS

The machine will always run with the constants adjusted in the factory. But there are different conditions from farm to farm and farmers also have different requirements. Therefore, some constants can be adjusted to the local wishes.

1. Slow start of turbine. Machine data no.13. Adjust the value to 4sec to start.

Now the valve for control of speed will close about half and continue to close stepwise until the adjusted speed is reached. Correct adjustment is: Continuously closing of the valve until the turbine starts running and stepwise until adjusted speed is reached.

2. Slow opening for the inlet of water. Machine data No. 17 . Set the value to 1. =

The opening is done stepwise.

3. Only 1 motor for speed regulation. Machine data no. 12. Value 0

Post-irrigation must take place as follow: when the stop sensor is activated only the retraction stops. When the post-irrigation is finished the machine starts again and runs to the mechanic stop.

4. Start of the 2nd machine when the 1st machine has reached stop.

Machine data No. 14. value 2.

The machine must be equipped with an adjustable pressure switch. Adjust the pressure switch to a point between the normal pressure and the pressure when the pump will stop. Example: the normal pressure is 7 bar, the pressure for pump stop 9 bar. Adjust the pressure switch to 8 bar on both machines. Start the 1st machine by pressing start. Adjust the 2nd machine, but press stop. When the first machine is ready the second machine starts as soon as its pressure has reached 8. Please note: 10 m of height difference make a pressure of 1 bar.

5. Stop of the machine when pressure is low and a pressure switch is mounted. Constant no.6 = value 1

Machine data No. 12 must be adjusted to a value of 2. Now the shut-off motor turns into the opposite direction. This means that when the cable connection stays the same the shut-off valve opens. After two minutes the shut-off valve closes again.

Only the combination of stop sensor, stop button and supervision can open the shut-off valve. The pressure switch, however, cannot open the valve.

6. Pre-irrigation before machine reaches the stop

Constant No. 9 can be set to the meter number where the post-irrigation should take place.



ATTENTION!

Open the front plate very carefully.
In order to ensure moisture protection by the cover gasket also the cover must be closed carefully!



ATTENTION!

Welding – and repair works at the RAINSTAR should only be done when the battery is disconnected!

7.6 STOP - SENSOR

The machine can only work if the stop sensor is activated or in operating position.

Operating position

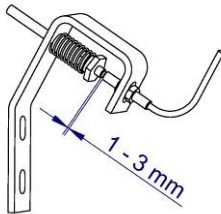

Shut-off position

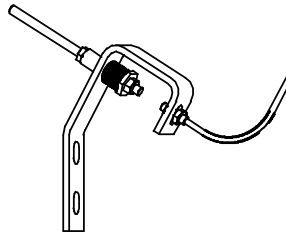

The Stop - Sensor has three functions:



1. Reset for the laid-down PE-pipe length:
When operated the laid-down pipe length is set to zero.
2. Post irrigation:
If the post-irrigation procedure is carried out at the end of the run (0 m laid-down PE-pipe length) the post-irrigation function is activated first and then the *ECOSTAR* is shut-off.
In the standard program the post-irrigation is activated 8m before the irrigation ends.
3. Prevents pulses to the regulating motor.
After the stop sensor is activated, no pulses are passed on to the regulating motor.

Press the key **MENU 2** x, to get to the display of menu 3. Her it shows if the speed sensors are working . The sign



shows if a magnet activated the two speed sensors.

Line four shows if motors 1 and 2 are switched off after they have reached their mechanical stop.

If sign  shows and one motor has not reached its end position there is a blockage on the inside of the turbine (MOTOR 1) or the valve(MOTOR 2). The motor switches off when the power consumption exceeds 4,7 ampere and  appears on the display.

If the display shows a flashing MOTOR 1 it means that the motor is running

SPEED	30.0m/h		
DOSE	22 mm		
TIME	14:10	STOP	7:43
STATUS MOTOR 1			

If the display shows a flashing MOTOR 2 it means that the motor for the shut off valve is running.

SPEED	30.0m/h		
DOSE	22 mm		
TIME	14:10	STOP	7:43
STATUS MOTOR 2			



By pressing the key PROG/POWER ON  or the PE-Pipe is laid out, the electronics is activated again.

The battery is charged only if the electronics is activated. There is no charging when in standby.

7.7 OPERATION OF THE BAUER ECOSTAR 4300

Summary:

- Pull off or lay down the PE – pipe
- Connect water supply
- Engage gearbox

ECOSTAR: make settings only in the standard menu:

Take over retraction speed from the last retraction or set again.



Press "START-RESET" key

Activate pre-irrigation if required
Activate post-irrigation if required
Open water inlet
Irrigation runs automatically

FURTHER OPERATING INSTRUCTIONS

After a longer standstill the electronic system of the *ECOSTAR 4300* is on standby.
Pulling off or laying down the PE – pipe activates the electronic system and the length of the pulled off or laid down pipe is metered.

For display of laid out PE-pipe, press key Menu 1 x:

DISTANCE	123M
BATTERY	12.8V
CHARGE ON	0.231A
PRE- 0:45	POST- 0:45

7.7.1 SPEED ADJUSTMENT

The pre-adjusted speed of 30 m/h can be increased or decreased with the arrow keys



At first the speed changes step by step for 0,1 m/h, then after ten steps there is a change of 1,0 m/h.

The speed can be changed at anytime while the machine is running.

The remaining time until the end of irrigation is also changed.

The speed cannot be changed while one of the servo motor for the turbine regulation or shut-off valve is running.

The display shows MOTOR 1 or MOTOR 2.

When changing the speed also the corresponding time changes.

SPEED	30.0m/h		
DOSE	22 mm		
TIME	14:10	STOP	7:43
STATUS	OPERATION		

Important!

When setting the speed it is necessary to check on the speed that is actually possible according to the test window (press menu key 3 x).

In case of variation the set speed must be reduced to the speed that is actually possible.

7.7.2 PRE – OR POST IRRIGATION



With the keys PRE – or. POST IRRIGATION these functions can be activated.

The time for the pre- and post is pre-programmed and is calculated by the *ECOSTAR 4300* as 8 times the time for covering a distance of 1 meter with the actual speed.

e.g: for $v_E = 20$ m/h there is a time of 3 min for 1 m retraction
 This makes a pre-irrigation time of 8×3 min = 24 min
 and a post irrigation time of also 8×3 min = 24 min

This value "8" can be changed in the program (program constant No 2 and No 3) –

See parameter sheet 1: constants.

If the pre irrigation function is activated, the machine runs approx. ½ meter after the start and then stands still for the pre irrigation time.



When pressing the button “START-RESET” , during pre-irrigation the pre-irrigation function is deleted.

Before activating the pre-irrigation mode the PE – pipe should be pulled off (the shut-off frame and thus also the shut-off sensor should be in the operating status) and the “START-RESET” key should have been pressed. If the post-irrigation mode is activated the machine stops 8m before the end of the run for the post-irrigation time. This value is pre-adjusted and can be changed in the program constant no.9, see parameter sheet 1: constants.



If you press the key “START-RESET” , the post irrigation is cancelled.

7.7.3 START

If the PE – pipe has been pulled off and the desired speed has been set you can start the irrigation with the



“START-RESET“ key.



If pre- or post- irrigation is required, press the following keys

The turbine can only start if the shut-off frame and thus also the shut-off sensor are in the operating state (PE-pipe pulled off).

If the „START-RESET“ key is pressed the turbine flap closes, the tooth segment on the regulating motor rotates to the limiting bolt head and the shut-off valve (if existing-optional) opens.

7.7.4 MONITORING

The program has a built-in monitoring system. It only works in connection with the shut-off valve- overpressure.

The standard factory setting of the monitoring is 20min. (parameter sheet 1, machine data 4). In this mode monitoring will start if the RAINSTAR does not reach the set speed within the programmed monitoring time. After this time the shut-off valve is closed and the machine stops. In most cases the reasons are excessively high retraction speeds or a blocked regulation flap etc.

In order to ensure that the set retraction speed is actually reached and the system is not switched off after the monitoring time, it is necessary to check the retraction speed that is actually possible by pressing the menu key three times.

If the system is equipped with a pressure switch the machine will start when a preset minimum pressure is reached, or it stops irrigating when water pressure is too low. As soon as the pressure returns to normal level, irrigation is continued.

7.7.5 STOP

At the end of the irrigation run the shut-off sensor is activated through shut-off frame and shut-off rods.

Sensor in shut-off position

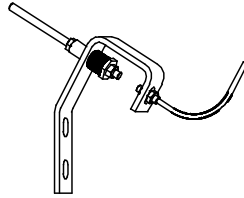

As a result the turbine stops and the shut-off valve overpressure closes slowly and remains in this position until the next operation.

If the RAINSTAR is connected to a hydrant you can release the water pressure which is remaining in the line after

closing the hydrant by pushing the „START-RESET“  key.

The shut-off valve opens and pressure is released through the PE-pipe.
If a low-pressure shut-off valve is mounted, it opens quickly.
It closes again after approx. 15 min.

By pressing the key „STOP“  the irrigation process can be stopped at any time.

The turbine flap opens (the turbine stops), the over-pressure shut-off valve closes, the low-pressure shut-off valve opens.

The laid down PE – pipe length remains saved. It is set to 000 only when the shut-off sensor is actuated (shut-off position).



ATTENTION !

If the „STOP“ key is used while retraction on a machine without shut-off valve the retraction stops but the sprinkler is still in operation. In order to prevent “over irrigation” around the sprinkler the machine should only work for a limited period of time without retraction. Then start the machine again by pressing the „START“ key!!



ATTENTION !

With machine data adjustments Pos. 12, adjustment „0“, the retraction stops only for a short period of time when pressing „STOP“ key. After a few seconds the retraction starts again automatically.

ATTENTION: when working on the machine the whole drive needs to be switched off!!

STOPPING THE CONTROL FUNCTIONS,

By pressing the keys „STOP“ and „PROG.“ at the same time all functions of the ECOSTAR stop, this means that the regulating motors of the turbine and the shut-off valve remain in their current position. With this combination of keys the turbine regulation is stopped when the turbine rotation speed is low in order to change gears.

7.8 PRESSURE SWITCH (OPTIONAL EQUIPMENT)

If the RAINSTAR, after having been positioned for the run, is supposed to start-up only after the required pressure has built up in the supply line (Pressure start) a pressure switch must be installed.

If such a switch is available, the monitoring system will also interrupt the irrigation cycle in case of low water pressure. As soon as the pressure returns to normal the irrigation is continued.

IMPORTANT: the pressure switch should only be used together with a shut-off valve over pressure!!

7.9 ERROR DESCRIPTION – ECO STAR 4300

Error	Cause	Remedy
Battery is not charging	Solar panel dirty	clean
	Solar panel defective	Leave machine in the sun Change solar panel
	Battery defective	Charge, exchange
Electronic system defective	Electronic error	Cover solar panel, Disconnect battery and connect it again.(reset) Call customer service, exchange E-Box
Device switches off early	Overwinding fault	Turn off water supply Slacken PE–Pipe Readjust machine
	Shut-off frame has been activated unintentionally	Put shut-off frame into the operating position, enter laid-down pipe length and press „START“
Retraction speed is not reached	Net or pump station does not have enough pressure	Increase pressure or enter retraction speed according to the performance chart
	Incorrect gear ratio	Change ratio
	Blocked turbine regulation	Remove foreign object

7.10 PROGRAMMING PROCEDURE

The electronic system is factory-programmed.

However, if site conditions require settings which deviate from these data it is possible to modify the program constants and machine data accordingly.

Proceed as follows:

In order to reach the constants the speed must be set at 11,1 m/h or 11f/h



Immediately press the "PROGRAMM"-key three times in order to get to program constant 0 (see parameter sheet No. 1)

By pressing the "PROGRAM"-key again shortly to select constant numbers 01 – 12 see parameter sheet No. 1.



With the arrow keys the values can be changed according to the requirements.



If you press the "MENU" key the changed constants are saved and the program returns to the standard display.

If you do not press "MENU" the changes **are not saved** and the program returns to the standard display after one minute.

The constants remain saved, even if the battery is disconnected for a longer time. The program constant 0 with the value 111 gives access to the machine data.



By pressing the key PROGRAM you can access the machine data mode.
See parameter sheet No. 2

By pressing the "PROGRAMM"-key again the machine data numbers 0 – 19 are selected.

With the arrow keys the values can be changed according to the requirements.

By pressing the key "MENU" the program returns to the standard display and saves the changed machine data.

If the key „MENU“ is not pressed the *ECOSTAR 4300* returns to normal mode after one minute and the adjustments of the constants are not saved.

CONSTANTS

Konst. Nr.	Anm.	Werks einstellung	Min. value	Max. value	Description
0		100	-	-	111 code for reaching the machine data
1		00:00	00:00	24:00	Time
2		8	1	15	Pre-irrigation
3		8	1	15	Post-irrigation
4		20	0	99	Monitoring time [Minutes] 0 = without shut-off valve , 20 = with shut-off valve
5		1	1	15	1 English, 2 Danish, 3 German, 4 French, 5 Dutch, 6 Swedish 7 Spanish, 8 Italian, 9 Polish, 10 Japanese
6		0	0	2	0 = slow shut-off, for option shut-off valve-over pressure 1 = fast switch off, for option shut-off valve low-pressure (shut-off valve opens and closes again after 3 minutes) 2 = without option shut-off valve
7		-	0	1000	input of the laid down pipe [m]
8		0	0	1000	Early stop [m] (* is carried out when post-irrigation has been selected*)
9		0	0	1000	Distance to post-irrigation [m]
10		0	0	1000	input PE-pipe length for alarm [m]
11		40	5	120	Amount of water [m ³ /h]
12		60	5	100	Distance between irrigation width [m]

The constant No. 0 (Code) must be set to 111 to get access to the machine data.
When pressing the key „PROG“-you get the machine data are shown.



ATTENTION!

If the water amount (according to performance chart) constant 11 and the distance between the irrigation tracks (strip width according to performance chart) constant 12 is not entered the dose indicated on the display is not correct.

MACHINE DATA

Machine.Dat	Anm.	Factory settings	Min. value	Max. value	Description
0		600	0	1000	Pipe length [m]
1		125	40	200	Pipe diameter [mm]
2		1850	500	3000	Reel diameter [mm]
3		11,27	5,00	30,00	Windings per layer
4		240	50	1000	Big chain wheel
5		9	5	40	Small chain wheel
6		4	1	20	Number of magnets
7		0,89	0,70	1,00	Pipe ovality
8		3	0	45	First impulse to the switch-off motor [Sec.]
9		160	0	300	Short impulses to the shut-off motor [msec]
10		3	1	5	Time between short impulses [Sec.]
11		100	0	250	Number of short impulses
12		0 1	0	1	Shut –off system 0 = only regulating motor turbine (without shut-off valve) 1 = both regulating motors (with shut-off valve)
13		8,2 4,1	1	25	Impulses to close the regulating valve [Sec] TX60 , TX100 - 8,2 sec. TX20 , TVR 20 , TVR 60, F 30, F 40 - 4,1 sec.
14		0 1	0	2	Pressure switch 0 = Pressure switch not in function 1 = Pressure switch in function 2 = Pressure switch only for start
15		0	0	160.0	62,5 Distance of the impulses with roll Ø 80 at the PE-pipe [mm] 0 = works with formula (Machine. Dat. 0 to 7)
16		1	0	1	Length sensor 0 = Round sensor for roll 1 = Double sensor
17		0 1	0	1	Open shut-off valve 0 = shut off valve opens with one impulse (12 sec.) –low pressure 1 = shut-off valve opens with the same impulses as it closes - overpressure
18		0 1	0	1	Pressure switch 0 = shut-off valve open when pressure is too low offen (low pressure) 1 = shut-off valve closes if pressure is too low (overpressure)
19		8	0	200	Time delay shut-off gear to shut-off valve [Sec].
20		0 1	0	1	Speed monitoring 0 = Monitoring off 1 = Monitoring on
21		0 1	0	1	Unit view 0 = metric units [m] 1 = US –unit [ft.]
30		0	0	1	0 = GSM-Modem not active 1 = GSM-Modem 2 = GSM-Modem, only numbers on the SMS-list
31		-	-	-	First telephone number to call „A“
31		-	-	-	Second telephone number to call „B“

7.11 BATTERY

In the factory a battery of 12 V and 6,5 ampere hours is mounted.

Charging the battery with a standard solar panel during the irrigation season is not necessary. Basically, the battery should be charged all 6 month with a charging current of max. 2 ampere. (Please note the maintenance and operating manual).

If the battery is connected the display shows for a short time e.g. "VERSION 4.1", and then goes over to standard display again.

In order to ensure a long lifespan of the dry battery of the ECOSTAR (LC-R 127R2PG 7,2 Ah/20 HR), it is important to follow certain guidelines when storing and charging the device.

During operation of the battery on the ECOSTAR no special precautions need to be taken as the solar panel permanently charges the battery.

1. Every new RAINSTAR irrigation machine delivered by BAUER, which is equipped with an ECOSTAR is also equipped with a fully charged and ready to use battery.
The solar panel, however, is covered and not connected to the battery. If there is a longer period of time between delivery and first operation the battery needs to be maintained. (see following points)
The same applies for spare part batteries and batteries which were held on stock for a longer period of time.
2. If the RAINSTAR is not in operation for a longer period of time, e.g. off season, the battery should be disconnected from the ECOSTAR and dismantled.
3. The accumulator battery should be stored fully charged, separate of conductive materials and out of the sun. If the accumulator battery is stored in an uncharged condition for a longer period of time the full capacity cannot be reached again after charging.
4. The optimum storage temperature lies between 0° and +25°. Also during storage the battery undergoes self-discharge and needs to be charged in the following intervals:

<i>Storage temperature:</i>	<i>Interval for charging:</i>
Less than +20°C	9 month
+20°C to +30°C	6 month
+30°C to +40°C	3 month

5. The humidity in the storage room needs to be low (55% +/- 30%) in order to prevent that the poles corrode.
6. A complete discharge of the battery should be prevented (deep discharge). The battery can be charged and reach its full capacity again but a repeated deep discharge the lifespan of the battery is reduced.
7. The accumulator batteries should be kept clean. For cleaning a dry cloth can be used, if required soaked in water or alcohol.
Under no circumstances use oil, petrol or diluents.
8. Accumulator batteries must not be disassembled as they contain acid which can cause strong chemical burns.
9. Accumulator batteries must not be hot-wired as they could be damaged.
10. Charging the battery should be done with a voltage of max. 2,0 A. If the battery is fully discharged the battery needs approx. 7 hours until it is fully charged.
Devices which check the capacity of the battery, as well as devices with an intelligent (self-regulating) charging function, enable an exact analysis as well as a controlled charging of the battery.

7.11.1 SOLAR PANEL

In the factory a solar panel is mounted which is maintenance free.

1. In order to ensure optimal performance the surface should be cleaned from time to time with a soft cloth and household cleaning agent (no scrubbing agent).
2. For operation the solar panel is unfolded and blocked. The solar radiation on the panel is more intensive. For transport of the RAINSTAR the panel is folded again. It is lifted and pressed to the machine and can be brought into its initial position where it is protected against damage.
3. In order to prevent over charging of the accumulator battery and a disturbance of the ECOSTAR, the electronic interrupts the charging process if the „STOP“ key is pressed or the accumulator battery is connected (When the machine is delivered the clamps are removed)

7.11.2 CHECKING THE CONNECTIONS

Press „START“ key.



The regulating motor closes (the segment turns to the limiting bolt)
 The shut-off valve overpressure opens.
 The shut-off valve low pressure remains closed.

Press „STOP“ key



The regulating motor opens the turbine (the segment turns away from the limiting bolt)
 The shut-off valve overpressure closes
 The shut-off valve low pressure opens

7.11.3 CHECKING THE LENGTH SENSOR

The magnet disc with 4 magnets is mounted on the drive shaft of the gear and rotates clockwise during retraction. By rotating the magnet disc clockwise the display for the laid down pipe needs to count from 0 m upwards. If the distance counter counts into the opposite direction then the speed sensor must be turned around in order that the cable connection is on top. Distance 1 - 3 mm between double sensor and magnet disc.

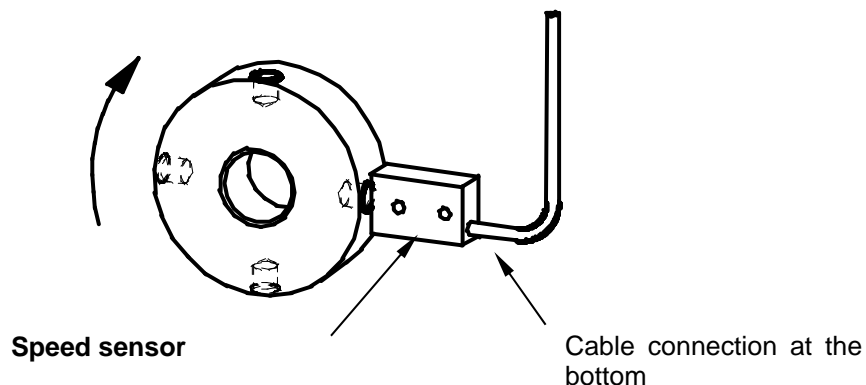

7.11.4 LIMIT STOP FOR TURBINES – REGULATING VALVE WITH ECOSTAR 4300

See point 6.5. The regulating area of the regulating valve of the turbine needs to be adjusted to the respective delivery rate. If the limit stop is not adjusted correctly it might happen that the turbine cannot be regulated, this means that the PE-pipe retraction happens with maximum speed.

If the flow rate is reduced significantly the limiting bolt head needs to be adjusted again, as otherwise the retraction speed listed on the performance chart cannot be reached.

You can see the required delivery rate on the performance chart fixed on the machine below the nozzle sizes.

7.11.5 SHORT CHECKLIST FOR ECOSTAR 4300

- 1. Check battery voltage (should be 12 V minimum)**
 - a) Cover solar panel completely
 - b) See battery voltage In test menu 1 (press MENU key once)
 - c) If there is no or not enough power available (below 12 V), check battery, cable connections or fuses inside the electronic box.
- 2. Check function of the sensors**
 - a) Set test menu 2 (press MENU key twice)
 - b) The display show indications for function control of the installed sensors , Motor 1 -Motor 2
- 3. Check length indicator of the laid down PE-pipe (press MENU key once)**
 - a) Read out the pipe length of the laid down PE-pipe on the standard display and compare with the engraved length indication on the PE-pipe.
 - b) If it shows 000 m, or significpless than the length of the laid out pipe, you need to make settings.
- 4. Check of the mechanic transmission to the stop sensor.**
- 5. Adjustment of the limiting bolt for the tooth segment of the regulating valve according to the chart fixed on the machine.**

8 OPTION - SMS

The ECOSTAR 4300 can be operated with an external MC52i-GSM-Modem by Cinterion.



By sending an SMS the RAINSTAR can be started or stopped and the status can be requested.

Commands

Start Starts the machine.
Stop Stops the machine.
Speed ### set the *speed* between 3 and 400 m/h., e.g.: **speed 24**
Status Shows the current status of the machine.

SMS can be typed in both upper- or lower case or mix .

If you call the modem from a GSM-telephone you will receive an SMS with the *Status*.

If the machine is operated by keyboard (display is lighted) the SMS-function is deactivated in order to prevent multiple sms and to block remote operating. When receiving an SMS **User active** is sent return.

Status

SPEED	30.0m/h
DOSE	22 mm
TIME	14:10 STOP18:16
STATUS	OPERATION
DISTANCE	123M
BATTERY	12.8V
CHARGE ON	0.231A

SMS, sent by PR10-12, contains information about irrigation.

The following messages are sent by SMS:

PRESSURE LOW: Start pump, to get pressure on the machine.
STOP SENSOR: The machine can be moved to a new field
STOP REMOTE: The machine was stopped by an SMS,
STOP DISTANCE: The machine has reached stop point (constant 8)
MONITORING TIME: The machine has not moved for nn minutes (Constant 4) due to a malfunction. Check the machine before continuing.

How to get started:

Disconnect electronic from battery.

Out the SIM-card unit an ordinary mobile phone and change the pin code to 1111.
 Try to send and receive an SMS in order to test SIM-card and to check if everything is working properly.

Insert the SIM-card into the modem.

Operate the eject mechanism (yellow button next to the card holder) to open the card holder by pressing it down with a pen, for example.

Insert SIM-card in the in den SIM-cardholder and push it back into the housing.

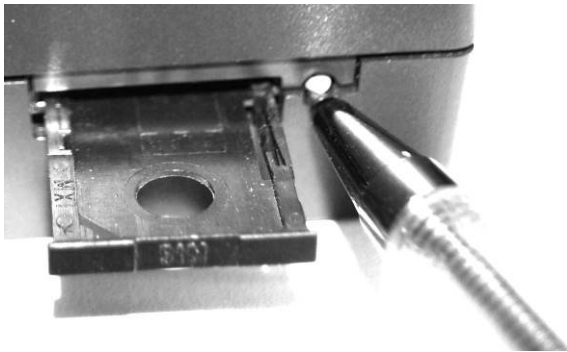

Connect communication-, power and antenna cable.

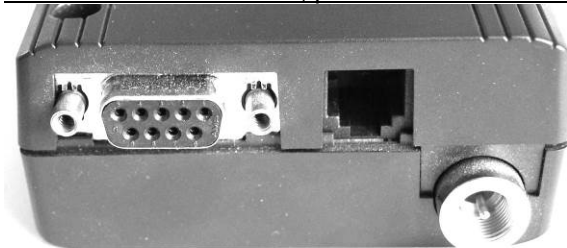

Connect the power and set machine data No.30

- 0 = GSM disabled
- 1 = GSM enabled, all telephone numbers are allowed, no *Speed* change possible.
- 2 = GSM enabled, only telephone numbers on sms list allowed -*Speed* change possible.

SPEED	11.1m/h		
DOSE	22 mm		
TIME	14:10	STOP	7:43
M.DATA	30	1	

To change machine data see operating manual.

If selected numbers are used they show on the display of the PR10-12, when receiving SMS from a phone. The number should always be entered in the same format e.g. +44213 ... 0044213 ... 213...

SPEED	11.1m/h		
DOSE	22 mm		
TIME	14:10	STOP	7:43
A:	+45123456		

To change machine data see operating manual.

After approx. 30-45 seconds the modem should be connected to network.

```
SIGNAL 23
NETWORK HOME
A: +45123456
B: +45234567
```

Signal strength 0 – 31 and network should show up in display menu 6.
 For trouble free operation a signal strength of 10 or higher is required.
 A signal strength of 99 indicates a signal error.

Modem has a LED showing status.

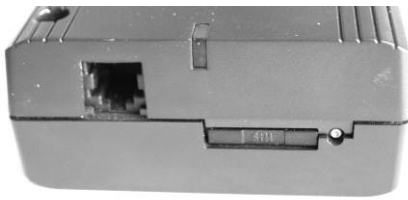

Operating states	LED
Off	Off
<ul style="list-style-type: none"> - Network search or -no SIM-card is inserted - no PIN is entered - no GSM-network is available 	Flashes rapidly
STANDBY (registered in the network)	Flashes slowly
Connection (TALK)	On

When a SMS is received, following is showed on display:

```
Receiving SMS
#: +45123456
Status
```

Receiving SMS, incoming phone number and 40 characters of a message. Any SMS can be received, but only known commands are accepted.

When a SMS is received, following is shown on the display:

```
Sending SMS
#: +45123456
Status Running
```

Sending SMS, outgoing phone number and current machine status.

New Modem from 2016

The ECOSTAR 4300 can be operated with an external **BGS2T GSM Modem by Cinterion**.

Insert the SIM into the SIM card holder until it snaps, hold, for example with a pen.

SIM can be removed from the cardholder by using a pen to carefully press the inserted SIM until it snaps out again.



Connect communication-, power and antenna cable.



Das **BGS2T GSM Modem by Cinterion** has a LED showing status.



Operating status	LED
GREEN On	On
YELLOW Off	Off
– Network search or – no SIM-card is inserted – no PIN is entered – no GSM-network is available	Flashes rapidly
STANDBY (registered in the network)	Flashes slowly
Connection (TALK)	On

9 CABLE CONNECTIONS –CONNECTION DIAGRAM

ECOSTAR 4300 18-Pol-Stecker			
Cable connection.	Version n.n1		
1 + Battery	brown	12 V	
2 - Battery	blue		
3 + Solar panel	blue		
4 - Solar panel	blue		
5 Motor 1	regulating motor		
6 Motor 1	regulating motor		
7 Speed sensor 1 *	blue		
8 Speed sensor 1 *	black		
9 Speed sensor 2 *	yellow/green		
10 Speed sensor 2 *	brown		
11 Stop sensor	blue or brown		
12 Stop sensor	blue or brown		
13 Motor 2	shut-off motor		
14 Motor 2	shut-off motor		
15 Pressure sensor	blue or brown		
16 Pressure sensor	blue or brown		
17 - BIP			
18 + BIP			
Cable connections for SMS			
19 + Battery	brown	+12 V	
20 - Battery	blue		
21 Not occupied			
22 Not occupied			
23 Not occupied			
24 Not occupied			
* if the distance counter counts into the wrong direction the speed sensor must be turned around.			



ATTENTION!

Attention: Power for modem only available if machine constant 30 is on 1 or 2 !!!

COMMUNICATION

Communication between ECOSTAR 4300 and GSM modem

!!! Do not put pins into the coupler strip before the cable on the ECOSTAR 4300 box is mounted!!!

1 not used	
2 data reception	brown
3 data transmission	white
4 not used	
5 mass	yellow
6 not used	
7 not used	
8 not used	
9 not used	

View of connector holes for pin insertion (shows pin numbers)

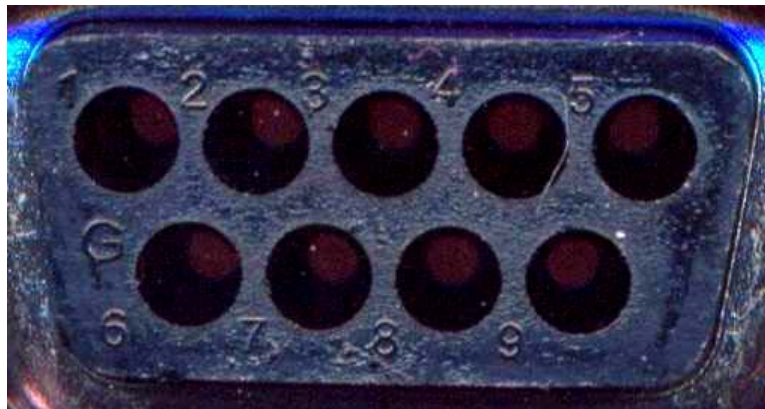

Antenna

The antenna providing signal for GSM modem, should be placed in a way it provides good signal under all conditions.

9.1 CHECKLIST FOR ECOSTAR 4300

During the first run at the start of the season, but also during normal operation, there can occur problems with the ECOSTAR, like negative reports, malfunction in connection with the electronics or the connected sensors, as well as problems due to operating errors.

A systematic check of the system according to the checklist below can help to identify and solve the problem quickly.

This checklist serves as an additional help to the detailed operating manual of the ECOSTAR 4300.

After checking the device according to the SHORT-CHECKLIST, handling instructions are in the list below.

Pos.	Error	Check and find cause	Remedy
1.	Wrong or incomplete display signal	<p>Check battery voltage!</p> <ol style="list-style-type: none"> The solar panel has to be covered completely and after 2-3 min the battery voltage can be checked on the display of the first menu window. (Press menu key 1x) <p>Note !</p> <ul style="list-style-type: none"> If the solar panel is not covered even an empty battery can show voltage on the display, or when the sun is shining a sufficient operating voltage is simulated. The power supply, however, is not sufficient for the system operation. <ol style="list-style-type: none"> If the voltage of the battery (not influenced by the covered solar panel) is below 12V, the power supply for the operation of the system is not sufficient. 	Charge or renew battery
2.	Display not working	<p>Check battery, cable connections and fuse!</p> <ol style="list-style-type: none"> Check battery voltage, battery is empty The connection cables between battery and ECOSTAR are not connected or without contact. The fuse is defective. The fuse is inside the electronic box where you can find a replacement fuse. <p>Note !</p> <ul style="list-style-type: none"> When checking the connections it is important that the cables are connected correctly: „+“ clamp = brown wire, „-“ clamp = blue wire. While disconnecting and connecting the battery and while the battery is disconnected the solar panel should also be covered, as an indication error is possible. The saved machine data remain saved when the battery remains connected. When connecting the battery again you must not mistake the „Plus“ and „Minus“ clamps, as a short circuit is possible and the fuse falls, or the electronic system can be damaged. 	Charge or renew battery; check connections and contacts Renew fuse

3.	Battery voltage permanently low	Check battery! 1. If the battery voltage remains low, although the solar panel is charging, check battery, charge battery or exchange it.	Check battery/charge or exchange.
4.	Charging error due to solar panel	Check solar panel! Notes ! <ul style="list-style-type: none"> • The normal charging function of the solar panel works as follows: when the battery voltage is 14,0 V or more the charging function switches off. On the display of the first menu window the sign „OFF“ appears when „charging with solar panel“ (1x MENU key) • If the battery voltage is 13,9 V or less, the charging function switches on and on the display appears „ON“ in the same menu window. • If the solar panel does not charge the battery although the voltage is 13,9 V or less, on the display „OFF“, the reasons are as follows: <ol style="list-style-type: none"> 1. There is not enough light and charging is not possible. 2. The „ + / - “ phases of the solar panel are reversed. The polarity should be measured. 3. The solar panel is defective. Determination by measurement at the exit of the panel. 	Correct polarity Change panel
5.	Unreadable notifications on the display	System voltage / start-up error 1. Low voltage may be the reason for unreadable notifications on the display . 2. This can also happen after first putting the device into operation or after connecting the battery again (even if sufficient voltage is available) Note ! Disconnect battery and solar panel, connect „+/-“,of the ECOSTAR cables (neutralize), after approx. 1 min. connect battery and solar panel again. Pay attention to the polarity of the cables!	Check battery voltage , charge battery Bring electronics in voltage-free state for approx. 1min.
6.	No length specification on the display	Shut-off sensor / loose PE-pipe windings 1. The PE-Rohr is completely pulled off, but the display shows 000 m. Notes ! a) In this case the shut-off frame on the RAINSTAR, or rather the shut-off sensor was activated and the pipe length display switches to 000 m and the ECOSTAR stops the operation of the RAINSTAR. The shut-off frame could also have been activated manually due to a loose PE-pipe- winding . b) The shut-off frame, or rather the shut-off sensor could also have been activated while pulling down the PE-pipe. In this case the length of the laid down pipe is shown, the shown value, however, is smaller than the actual length of the pulled off pipe. The value must be entered again as described below. c) If the length is not counted when pulling off the pipe the value cannot be corrected and the RAINSTAR does not start. In this case the shut-off sensor is not adjusted correctly (distance too short, see operating manual) PE-pipe length specification at the ECOSTAR Proceed as follows (see also operating manual) a) Set retraction speed to 11,1 m/h b) Press the key PROGRAM 3x, this way parameter sheet no.1 shows, by pressing the key PROGRAM again you get to constant 7.	Set PE Pipe- Length on the ECOSTAR again

		<p>c) In this position the value of the constants can be adjusted to the laid down PE-PIPE length by pressing the the arrow keys. The actual length of the laid down pipe is imprinted on the PE-pipe on the RAINSTAR.</p> <p>d) With the key TEST the set value can be saved and the display goes back to standard again. The RAINSTAR can be started again.</p>	adjust shot off sensor correctly or change
7.	No length shown on the display or length is counted incorrectly	<p>Length sensor</p> <p>1. If the length is not counted when the PE-pipe is pulled off or the indication is wrong (indicated length increases instead of decreases) the length sensor is mounted incorrectly (see instructions with drawing in the operating manual)</p>	Mount length sensor correctly
8.	Length indicated on the display does not match with the actual length of the laid down PE-pipe	<p>PE-pipe ovality</p> <p>1. The length of the laid down PE-Pipe and the value shown on the display always show the same percentage share of difference. I this case the ovality of the pipe does not accord with the set value and must be corrected.</p> <p>Correction of the ovality constant</p> <p>a) To correct it go to parameter sheet no.1 like described under pos.6, press the PROGRAM key until constant 0, if you enter the value 111 in this constant you get to parameter sheet no.2, to the machine data. Under machine constant 7 the ovality value can be corrected. .</p> <p>b) If the length indicated on the display is always higher as the actual length of the laid down pipe, the ovality is higher than programmed The factor needs to be corrected from 0,89 to 00,88 or 0,87.</p> <p>c) If the length indicated on the display, however, is always lower than the actual length of the laid down pipe, the ovality is lower than programmed. The factor has to be corrected from 0,89 to 0,90 or 0,91.</p> <p>Length sensor / Magnet disc</p> <p>2. The length of the laid down PE-pipe and the value shown on the display always differ significantly.</p> <p>Note !</p> <p>a) On the magnet disc there are missing one or more magnets. The magnet discs are equipped with 4 magnets, this applies to all ECOSTAR models.</p> <p>b) One or more magnets are no longer active. If the magnets move past the length sensor on the display in the menu window there is no signal for one or more magnets on the display (2xMENU key) (■)</p> <p>c) In the machine data the number of magnets is programmed with a different number than 4. On the parameter sheet no.2, the factor 6 needs to be corrected to 4 (see exact procedure in operating manual)</p> <p>On the display there is no signal at all (■). The length sensor is defective.</p>	<p>Correct ovality factor</p> <p>Reduce ovality factor</p> <p>Increase ovality factor</p> <p>Complete magnets</p> <p>Exchange inactive magnets</p> <p>Correct machine data, exchange length sensor?</p>
9.	Electric shut-off valve does not close	<p>Shut-off sensor</p> <p>1. If the electronic shut-off valve (overpressure shut-off) does not close at the end of the irrigation strip (open in case of low pressure shut-off) the shut-off sensor is not adjusted correctly (Sensor distance too small). In the menu window the sensor signal does not go away (■).</p>	Adjust shut-off sensor

10.	Electric shut-off valve does not close or open	<p>Program constant</p> <ol style="list-style-type: none"> The ECOSTAR is not programmed for a shut-off valve. On the parameter sheet no.1.under program constant 6 appears setting „2“. The constant needs to be corrected to „0“ (with shut-off valve overpressure) Furthermore on the parameter sheet no.2 under machine „12“ the following value must be entered: „1“ for both regulating motors (with shut-off valve) <p>Pressure switch</p> <ol style="list-style-type: none"> If a pressure switch for a shut-off when pressure is low is installed the reasons could be the following: <ol style="list-style-type: none"> Not enough pressure for operating, the pressure is below the value which was adjusted at the pressure switch RAINSTAR. Pressure switch dirty or defective. In order to check the function of the pressure switch, the pressure switch can be put out of operation in the program parameter sheet no.2, constant 14, with adjustment „0“. <p>Dirt / Foreign bodies / Connections</p> <ol style="list-style-type: none"> The shut-off valve is mechanically blocked by foreign bodies. The electronic connections of the shut-off valve are defective or not correctly installed. Motor for valve (Motor 2) defective 	<p>Correct adjustments</p> <p>Increase pressure Clean switch / change</p> <p>Clean flap Check connections Check motor/ change</p>
11.	Turbine regulation does not work, valve remains open or closed	<ol style="list-style-type: none"> Limiting bolt for the adjustment of the regulating valve is not adjusted correctly, valve is closed too much and cannot be opened by the motor. (See adjusting table for turbines TVR 60, the adjustment depends on the discharge flow) Electronic connections to the motor (Motor 1) are defective or not correctly installed. Motor for regulation valve (Motor 1) defective Foreign bodies disturb the function of the regulation valve. 	<p>Adjustments of the bolt according to table</p> <p>Check connections/ change Remove foreign body</p>
12.	Machine stops during operation	<ol style="list-style-type: none"> If the machine is equipped with a pressure switch, the machine can stop if the inlet pressure is too low. If the operation of the machine should be continued, the function of the pressure switch can be switched off. If the required (set) retraction speed is too high and the machine can not reach it, for a period of 20min, the machine switches off as well. This function, however, can be switched off: Machine data, parameter sheet no.1, constant 4 (monitoring of correct speed) Adjustment e.g „20“ monitoring switched on Adjustment „0“ monitoring switched off 	<p>Increase connection pressure, switch off pressure switch</p> <p>Reduce retraction speed</p> <p>Switch-off monitoring</p>
13.	Further open questions	<p>If further problems with the display, accuracy or other functions should occur the set data of the ECOSTAR according to the constants of parameter sheet no.1 and the machine data of parameter sheet no.2 need to be checked. If necessary please contact our customer service.</p>	

9.2 TABLE FOR PRE-AND POST-IRRIGATION

In order to correct irregularities at the beginning or at the end of the irrigation strip the ECOSTAR has the function pre- and post-irrigation. The precipitation height at the beginning of the strip (pre-irrigation) and at the end of the strip (post-irrigation) is reached by short interruptions of the cart retraction. The downtime for the pre-and post-irrigation is adjusted at the ECOSTAR with the program constant 2 and 3 on the parameter sheet no.1. The program constant 8 was pre-set in the factory.

This factor links the retraction speed of the sprinkler with the pre- and post-irrigation time. The adjusted factor can be changed, whereby pre- and post-irrigation changes.

The following table shows the pre-and post-irrigation times in minutes (rounded) at different adjustment factors:

Program constant	Retraction speed in m/h Pre-and post-irrigation time in min.									
	10 m/h	20 m/h	30 m/h	40 m/h	50 m/h	60 m/h	70 m/h	80 m/h	90 m/h	100 m/h
1	6,0	3,0	2,0	1,5	1,2	1,0	0,9	0,8	0,7	0,6
2	12,0	6,0	4,0	3,0	2,4	2,0	1,7	1,5	1,3	1,2
3	18,0	9,0	6,0	4,5	3,6	3,0	2,6	2,3	2,0	1,8
4	24,0	12,0	8,0	6,0	4,8	4,0	3,4	3,0	2,7	2,4
5	30,0	15,0	10,0	7,5	6,0	5,0	4,3	3,8	3,3	3,0
6	36,0	18,0	12,0	9,0	7,2	6,0	5,1	4,5	4,0	3,6
7	42,0	21,0	14,0	10,5	8,4	7,0	6,0	5,3	4,7	4,2
8	48,0	24,0	16,0	12,0	9,6	8,0	6,9	6,0	5,3	4,8
9	54,0	27,0	18,0	13,5	10,8	9,0	7,7	6,8	6,0	5,4
10	60,0	30,0	20,0	15,0	12,0	10,0	8,6	7,5	6,7	6,0
11	66,0	33,0	22,0	16,5	13,2	11,0	9,4	8,3	7,3	6,6
12	72,0	36,0	24,0	18,0	14,4	12,0	10,3	9,0	8,0	7,2
13	78,0	39,0	26,0	19,5	15,6	13,0	11,1	9,8	8,7	7,8
14	84,0	42,0	28,0	21,0	16,8	14,0	12,0	10,5	9,3	8,4
15	90,0	45,0	30,0	22,5	18,0	15,0	12,9	11,3	10,0	9,0

10 WINDING MECHANISM

The winding mechanism operates synchronously with the winding or unwinding of the PE-pipe. Starting from the reel it is operated through a chain and the helically grooved spindle transporting the winding carriage of the PE-pipe. The winding mechanism ensures that the PE-pipe is properly guided winding for winding. When you put the machine into operation for the first time, pull off the full length of the PE-pipe to let it take a circular shape under pressure. This step is essential for trouble-free operation of the winding mechanism.

10.1 ADJUSTMENT OF THE WINDING MECHANISM

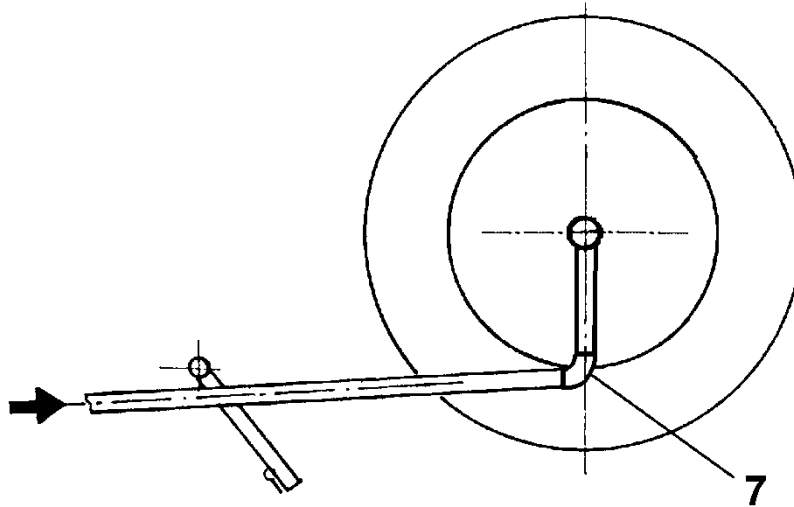

Step 1:

Pull off the PE pipe and position the connecting bend (7) vertically pointing down.

Step 2:

Slacken the winding chain (1) between the reel and the helically grooved spindle (2).

Step 3:

Fasten both guide tubes (4 and 5) symmetrically at distance **X 2** to the guide part (3).

Mount the roller bracket (6) with the roller.

Step 4:

Move the guide part (3) of the winding carriage to the outermost reversing point of the groove to the right by turning the helically grooved spindle (2) Value **X 1**.

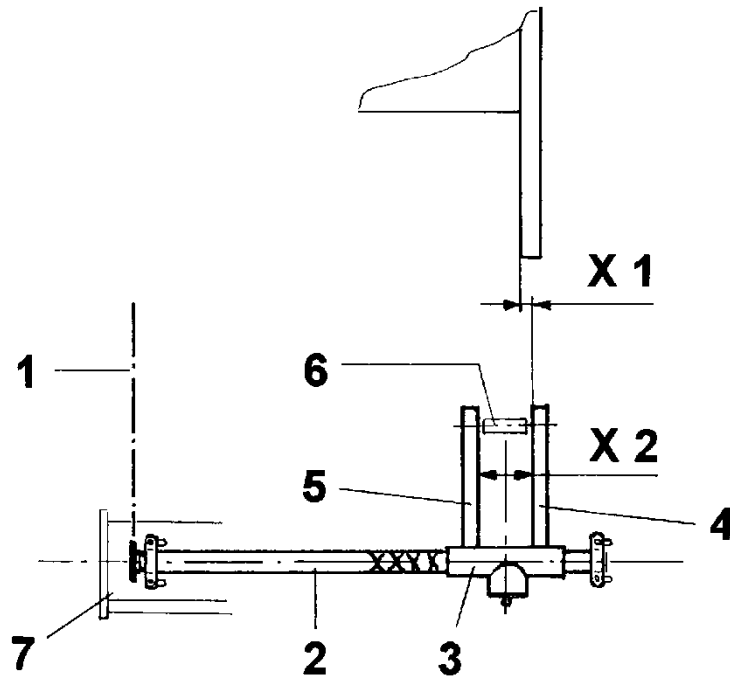

PE - pipe Ø		X 1	X 2
65	T 32	10 mm / 0,39 inch	95 mm / 3,74 inch
75	T 32, T 42	10 mm / 0,39 inch	95 mm / 3,74 inch
85	T 42	10 mm / 0,39 inch	105 mm / 4,13 inch
90	T 42	10 mm / 0,39 inch	110 mm / 4,33 inch



WARNING!

When using a PE-pipe repair coupling you must increase the spacing x 2 symmetrically by 15 – 20 mm / 0,59 – 0,79 inch.

Step 5:

Adjust the right guide bar at x 3 to the edge of the inner reel wall by turning the helically grooved spindle. (see chart)

PE – Rohr Ø		X 3
65	T 32	0
75	T 32, T 42	0
85	T 42	0
90	T 42	0

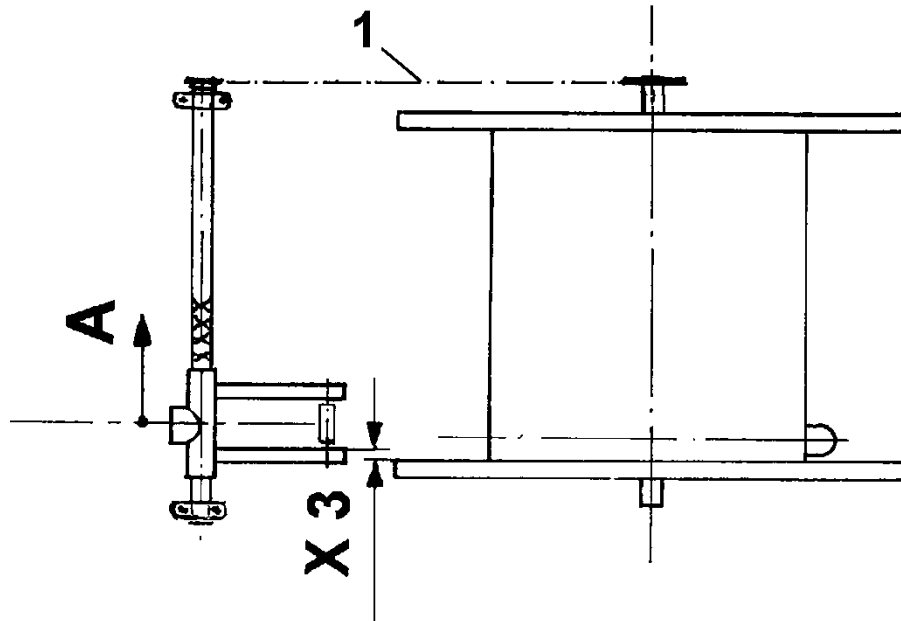



WARNING! In doing so, the spindle must be turned in wind-up direction (counter-clock-wise, see drawing).
At this point, the winding carriage moves from the reversing point to the left (direction A).

Step 6:
Mount the winding chain (1) , reel unchanged with inlet bend pointing down.
Tighten the winding chain (1).

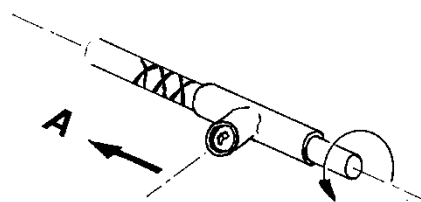

11 SHUT-OFF AND SAFETY EQUIPMENT

Unattended performance of the RAINSTAR is made possible by a final and safety shut-off. The final shut-off is actuated when the sprinkler cart presses against the shut-off frame, which in turn operates the gear shift lever through a linkage. This way the drive is stopped.

To avoid troubles caused by faulty windings of the PE-pipe on the reel, shut-off is also activated by the shut-off frame when faulty pipe windings build up on the reel.

11.1 SETTING INSTRUCTIONS FOR SHUT-OFF

Gearbox G 3-4

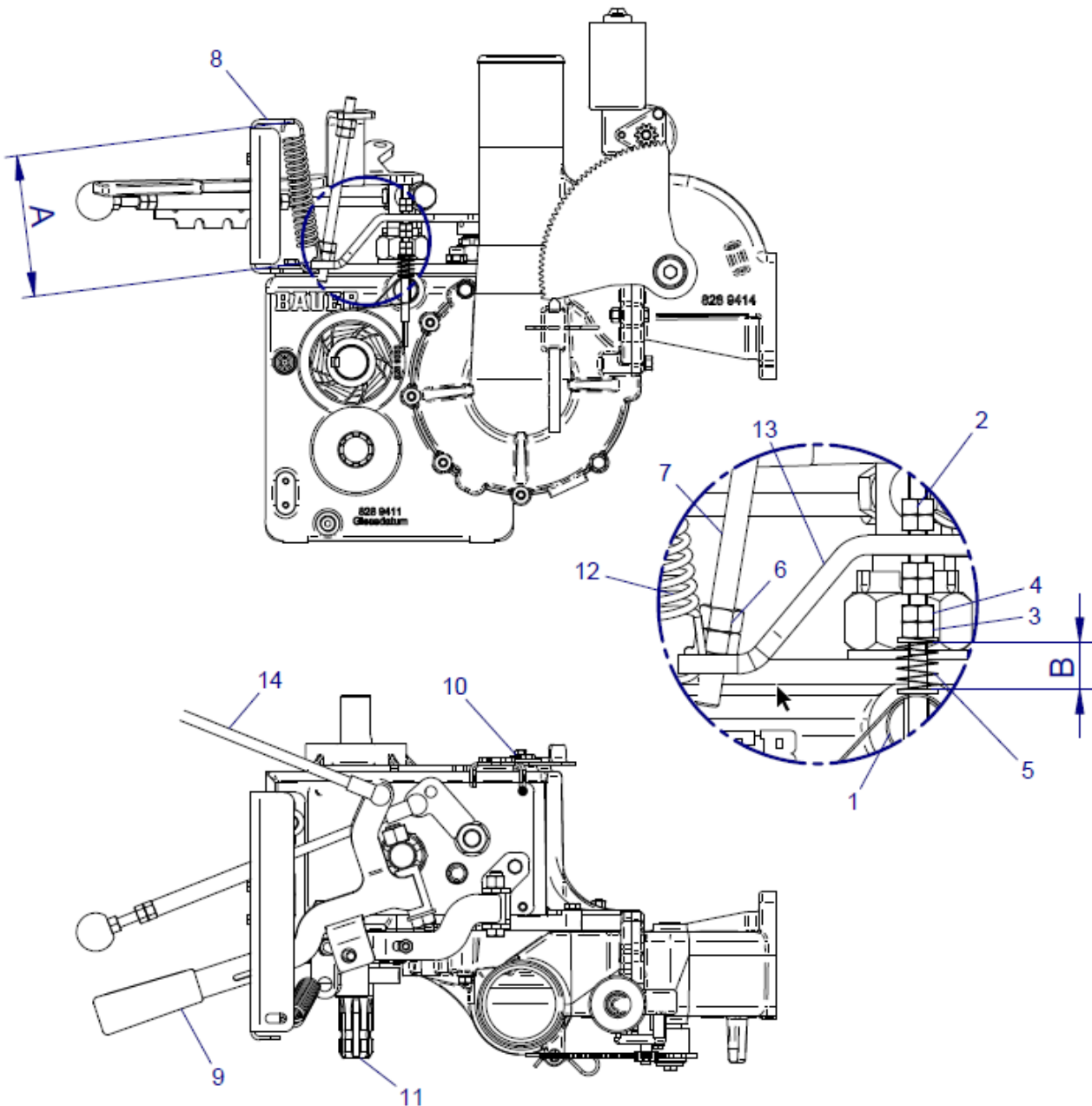

11.2 SETTING THE SHIFTING GATE

The shifting gate (8) must be adjusted to the shut-off point of the gearbox.

Procedure:

Move the shut-off lever (9) in position "PE – pipe retraction"

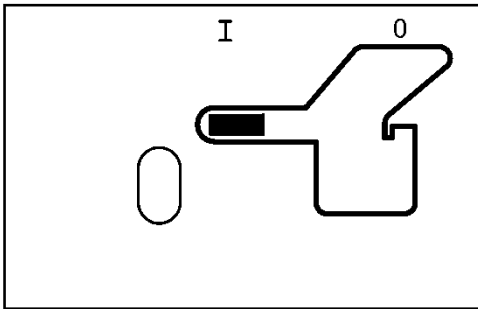

Actuate the inlet shaft (10) – the PTO shaft (11) will also start rotating“.

Shift the shut-off lever (9) slowly in position „0“.

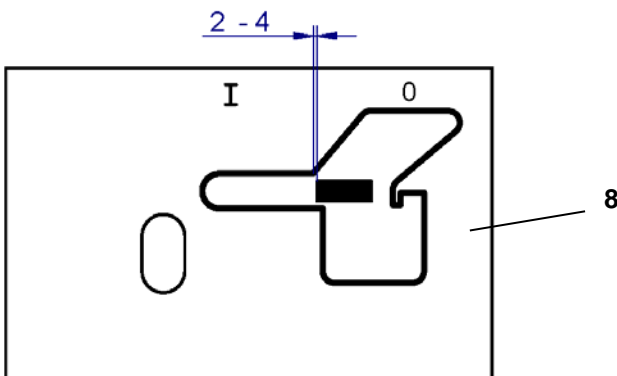

The shut-off point is reached when the PTO shaft no longer rotates.
Set the shifting gate (8) in this position according to the drawing (2 mm / 0,08 inch) !

The spring (12) presses the shut-off lever (9) upward along the incline of the shifting gate and this way also into the recess in the gearbox.

11.3 SETTING THE BAND BRAKE ON THE GEAR BOX

Place shut off lever into shut off position.

Pull the hexagon nuts (2) of the band brake, until the pull spring (12) has a length of **A = 140 mm / 5,51 inch** (2) secure the hexagon nuts

Pill the hexagon nut (3) until the spring(5) with **B = 20 mm / 0,79 inch** is biases, secure with nuts (4).

11.4 SETTING THE BREAK LEVER TO VENTILIZE THE PE-PIPE

Put the shut-off lever into the unwind position of the PE – Pipe .

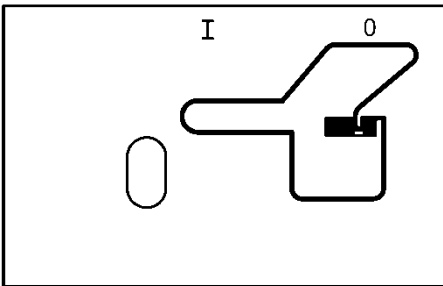

Setting the distance $C = 3 \text{ mm} / 0,12 \text{ inch}$ between break lever (13) and nut (4).
Secure the hexagon nuts (4).

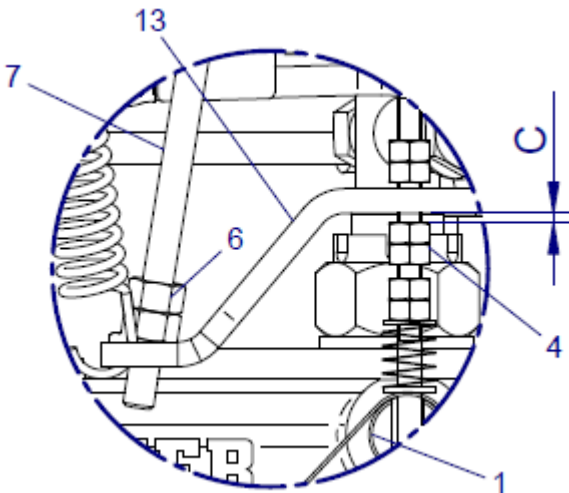

11.5 SETTING OF THE THREADED ROD

The hexagon nuts (6) on the threaded rod (7) must be twisted back, to reach a distance of 10 mm between shut –off lever and the shifting plate(8) according to the sketch.
Secure the hexagon nuts (6).

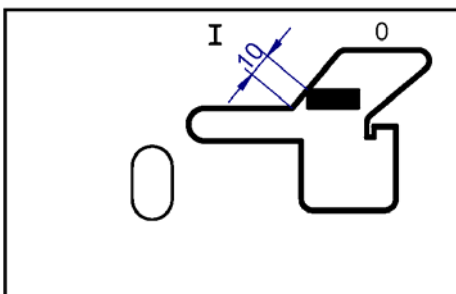

11.6 INSPECTION OF THE BAND BRAKE FOR RELEASE OF THE BAND BRAKE

Move shut-off lever (9) to the “Release” position.

In this position the band brake must be slightly lifted off the brake disc. This prevents the brake band from sticking to the brake disc !

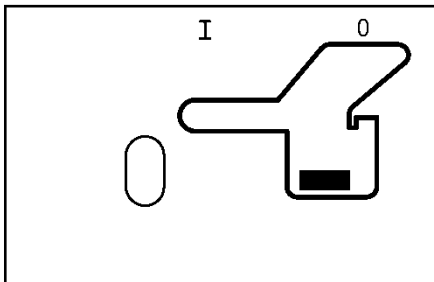

CAUTION!

The band brake may stick after a longer stand-still or after the winter period. It must be loosened before putting the machine into operation again !!! Do this by shortly turning the PTO shaft to the right and the left with the hand wheel. Non-observance can cause the gear box to break !

11.7 SETTING THE GEARBOX SHUT-OFF

The speed compensating bar(13) is set at **X** mm distance to the reel (17) in **shut-off position**.

Set the locking lever (20) in position **Y** to the lift hook guidance (see chart)

Screw down the screw (18) and lock with nut (19).

Switch the shut-off lever (9) into shut-off position.

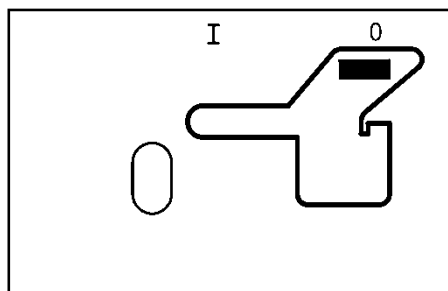

Screw down the hex. nut (15) on the switch bar (16) to the bracket of the shut-off frame.

Lock the nut.

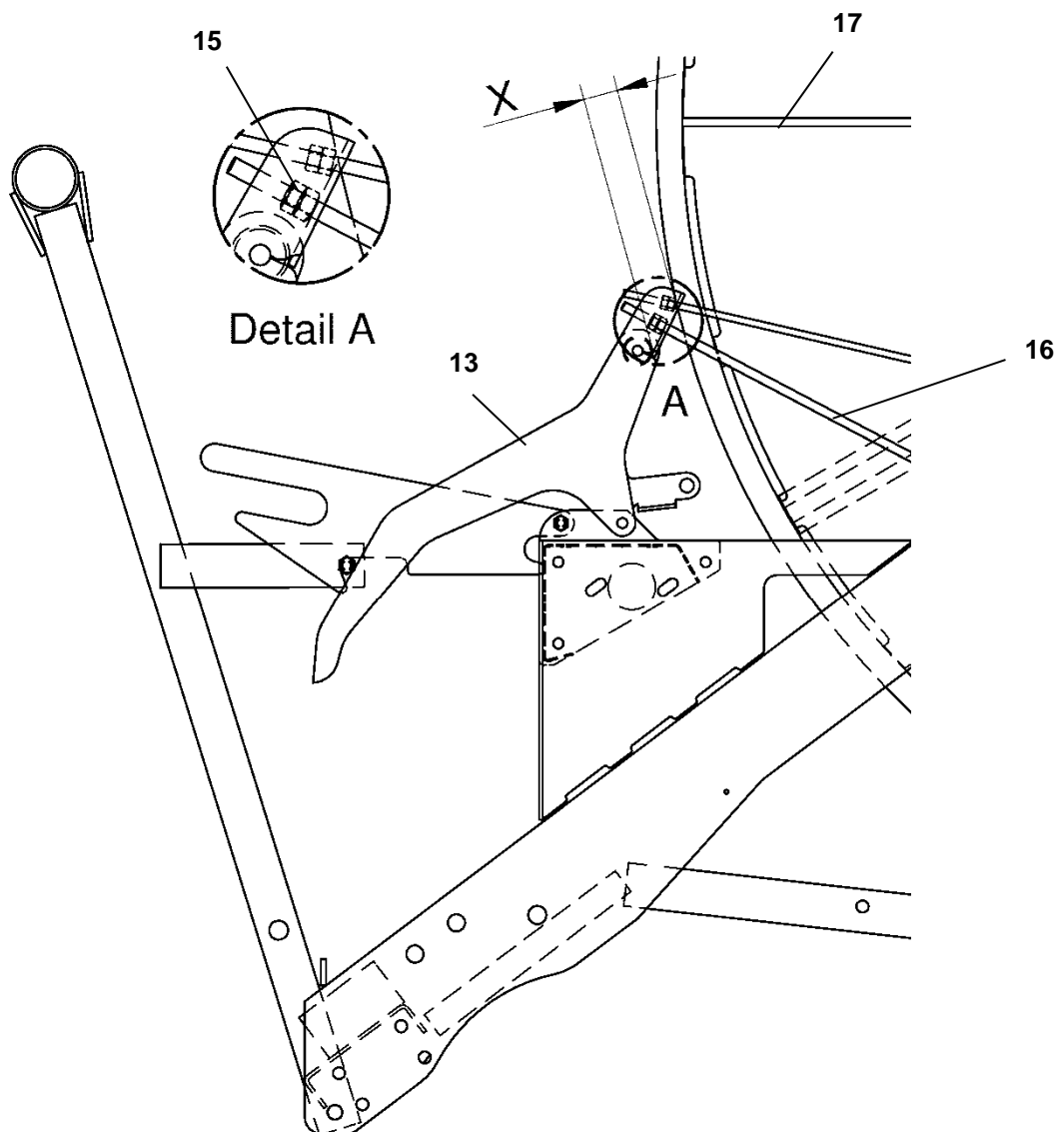

11.8 INSPECTION OF THE SHUT-OFF

Put the speed compensating bar (13) against the PE pipe (last layer)

Move the shut-off lever (9) in „PE-pipe retraction position“.

Pull the speed compensating bar (13) into the shut-off position

X = 40 mm from the reel

The shut-off lever must jump into the shut-off position!

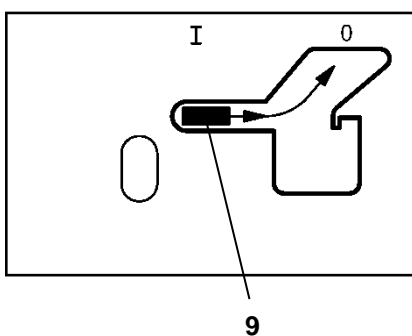

12 SETTING TURBINE BRAKE

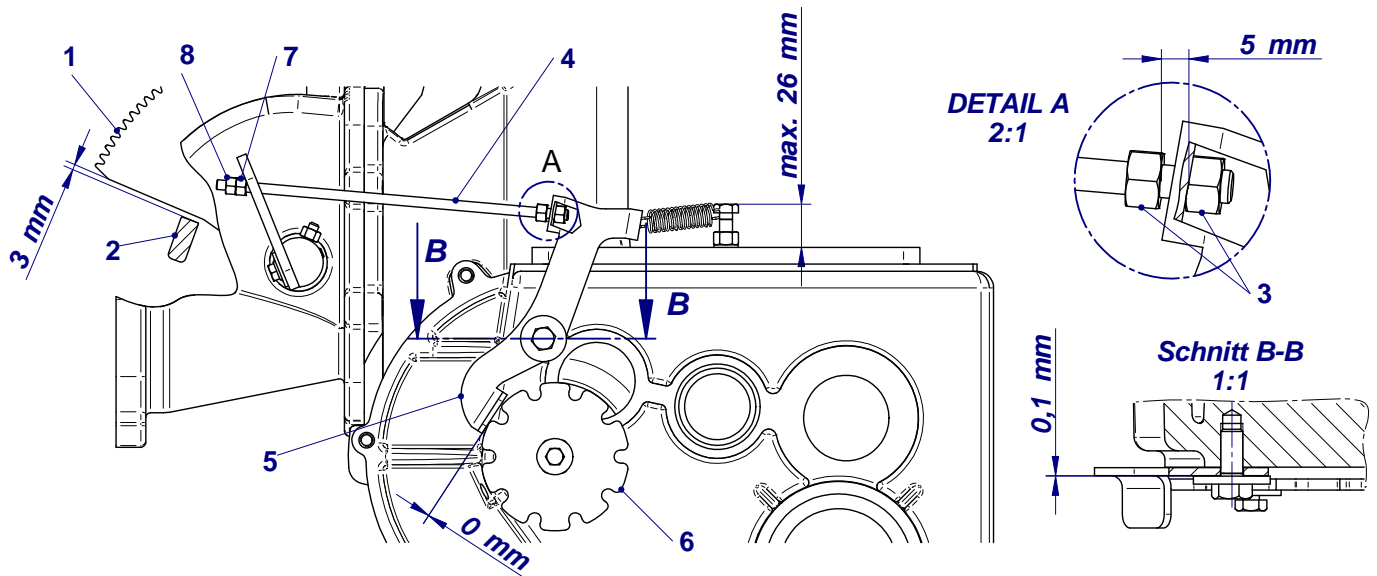

1. Enclose a spacer of 3mm between segment (1) and end stop (2)
2. Set a distance of 5mm (DETAIL A) between the two nuts (3) on the threaded rod (4).
3. Then adjust the nuts (7) on the other side of the threaded rod (4) until the value "0" is reached between breaking lever (5) and breaking wheel (6). Then secure the nut (7) with the second nut (8).
4. Remove the spacer of 3mm between segment (1) and end stop (2).

13 STATIV

High construction of both symmetric and asymmetric wheel carts provides maximum crop protection (asymmetric wheel cart OPTIONAL). With infinitely variable track width you can adapt the carts to crop row spacings of over 3.0 m with the symmetric design, and up to 2.0 m with the asymmetric design.

For easier pulling the cart is fitted with a draw-out hook.

You pick up the cart at this hook with the tractor's toolbar and pull off the PE-pipe.

For turning the pipe reel and placing the RAINSTAR in a new setting-up position, the cart must be in its end position (raised).

Depending on the type of sprinkler, the nozzle height of the sprinkler is:
approx. 1860 – 1960

At the end of retraction the cart is lifted automatically. Owing to its pendulous mounting the sprinkler is not tilted but always remains in the optimum position regarding distance of throw and distribution uniformity. This pendulous mounting assembly compensates also slopes in the terrain in longitudinal direction

14 OPTIONAL EQUIPMENT

14.1 OVERPRESSURE SHUT-OFF VALVE (OPTIONAL ON ECOSTAR)

With the overpressure shut-off valve, water supply to the machine is turned off completely at the end of the irrigation run.

- a) When the cart reaches the shut-off position or when the machine is turned off by means of a pressure switch (optional), the overpressure shut-off valve closes in response to an electrical pulse from the ECOSTAR.
- b) The shut-off valve closes slowly in order to avoid pressure shocks.
- c) Pressure in the supply line increases. The pump must be shut off automatically by means of a pressure switch (or flow control).

14.2 LOW PRESSURE-SHUT OFF VALVE

With the low pressure shut-off valve a shut off valve is opened quickly after the irrigation process and a high amount of water is being drained out. The pressure in the discharge line is being reduced drastically (almost half of). Due to the loss of pressure the pumping aggregate is being switched off by a pressure switch and the pumping is being stopped. This valve can only be used in combination with a pressure switch for the automatic shut off installation for the pump.

CAUTION!

The low pressure shut off valve can only be used if only one irrigation machine is being supplied by the pump. If more than one machines are supplied by the pump the low pressure shut off valve cannot be used!

14.3 COMBINED SHUT-OFF

The combined shut-off combines overpressure and low-pressure shut-off in one system. The double supply line allows both overpressure and low-pressure shut-off at the end of the irrigation strip.

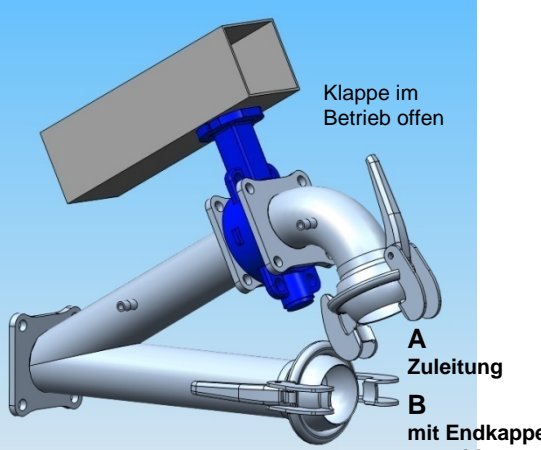

Klappe im
Betrieb offen

A
Zuleitung
B
mit Endkappe
verschlossen

. OVERPRESSURE SHUT-OFF:

- a) Inlet through supply line „A“
- b) Supply line „B“ is closed with an end cap
- c) The ECOSTAR is programmed for overpressure shut-off parameter sheet no.1, program constant 6, setting value „0“
parameter sheet no.2, machine data 17, setting value „1“
- d) The shut-off valve is opened during operation.
- e) The shut-off valve closes slowly for the shut-off. Pressure rises in the supply line. The pump must be shut down automatically by means of a pressure switch (or flow control).

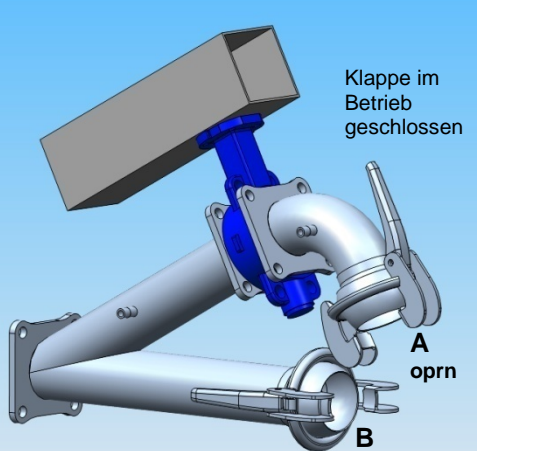

Klappe im
Betrieb
geschlossen

A
oprn
B
inlet

LOW-PRESSURE SHUT-OFF:

- a) Inlet through supply line „B „
- b) Supply line „A“ remains open.
- c) The ECOSTAR is programmed at low-pressure shut-off. parameter sheet no.1, program constant 6, setting value „1“
parameter sheet no.2, machine data 17, setting value „0“
- d) The shut-off valve is closed during operation.
- e) The shut-off valve opens quickly for shut-off. Pressure in the supply line drops. The pump must be shut down automatically by means of a pressure switch..

15 WINTERIZATION – DRAINING

In areas where frost is likely in winter after the irrigation season, the machine must be drained in time. A compressor with a minimum air capacity of 800 l/min at 2.5 bar overpressure is best suited for this purpose. Connect the compressor to the inlet of the machine. For blowing out the water the PE-pipe should not be pulled off. It can stay on the reel. Otherwise, winding up the pressureless PE-pipe would cause extreme ovality and proper winding would become impossible.

Before the blow-out procedure, uncouple the sprinkler connecting hose. The small amount of water remaining in the PE-pipe after the draining will not do any harm.

Turn out the drain plug at the bottom of the TVR 20 turbine. We recommend to turn this plug in again only when you start up the machine at the beginning of the next season. If a hydraulic shut-off valve is mounted, the thin connecting hoses also have to be drained by opening the screwings. Open the blind flange at the RAINSTAR connection. Clean the RAINSTAR and regrease all appropriate points. Store the machine preferably in a roofed shelter where it is protected from direct exposure to the weather.

16 SERVICE AND MAINTENANCE

We cannot emphasize often enough that proper service is essential for the operating reliability and service life of a machine. At the end of every irrigation season the RAINSTAR should be thoroughly checked and cleaned, and all parts re-greased carefully.

Machine part	Service interval	Lubricant, grease, oil
1. Helically grooved spindle of the winding mechanism	every 250 hours	multi-purpose grease (Alvania Grease)
2. Drive chain of winding mechanism	every 250 hours	multi-purpose grease (Alvania Grease)
3. Lubrication the reel seal	greased twice every season	multi-purpose grease (Alvania Grease)e
4. Driver (spindle nut) of winding mechanism	every 250 hours, change recommended after 2500 service hours	multi-purpose grease (Alvania Grease)
5. Driving chain	as required	multi-purpose grease (Alvania Grease)
6. Change-speed gearbox	Change oil for first time after 500 service hours and then every 500 to 800 hours or at least once a year	Gear lubricant oil CLP – DIN 51517 – Teil 3, ISO VG 220 – 6,3 l
7. Ball race	every 500 hours	through grease nipple multi-purpose grease (Alvania Grease)
8. Jack	as required	multi-purpose grease (Alvania Grease) through grease nipple
9. Shut-off point on the cart lift bracket	as required	multi-purpose grease (Alvania Grease)
10. Bolted joint		Tightening torques
Turntable side frame		210 Nm
Ball race on turntable and undercarriage		85 Nm
Trailer coupling		210 Nm

16.1 INSTRUCTION FOR LUBRICATING THE REEL SEAL

In order to ensure durable and trouble-free functioning of the reel seal, it must be greased twice every season

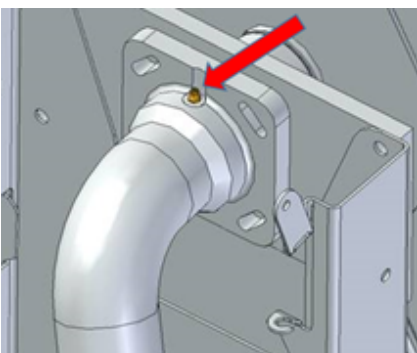

17 TECHNICAL DATA

Machine Dimensions T

Basic model	Height	Width	Length with cart	Length without cart	Clearance	Tyres	Track width h	Height	Length drum cart	Length without drawbar eye
	A	B	C	D	E			I	G	H
T 32	2600	1950	5370	3720	260	195/70 R14	1500-2000	2330	2510	3540
T 42	2850	1950	5370	3720	275	205 R 14 C		2560	2670	3540

NOTE: for devices T32, T42 reel rotatable with track 1500 - 1800 mm

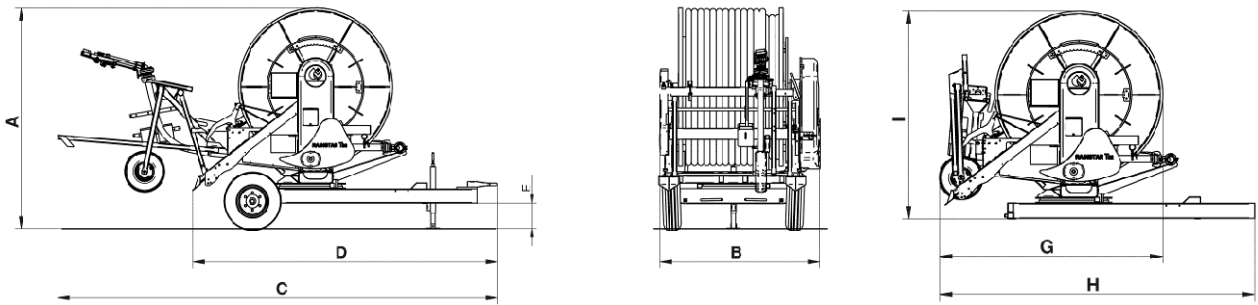

Drawbar coupling height

Basic model	Eye bottom mounted [A mm]	Eye top mounted B [mm]	+ with adapter C [mm]
T 32	220	500	750
T 42	240	520	770

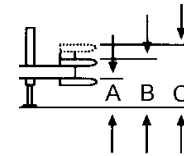

symmetrical

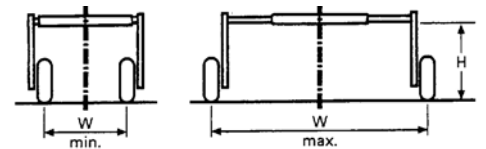

Cart dimensions

Basic model	Track width height	Sym. cart	asym. cart	tyres
T 32, T 42	W H	1200-3000 (3800) 1100	1200-2000 1100	165/70 R13

asymmetrisch

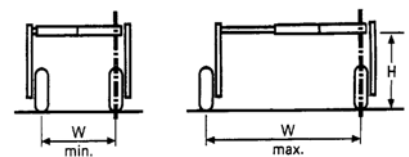

RAINSTAR T Indication of Tyre Pressure

To secure long durability of the tyres and safe transportation of the RAINSTARs it is important to give the tyres sufficient air pressure.

Standard RAINSTAR T

Model	Tyre size	Required Tyre Pressure
T 32	195 / 70 R 14	2,7 bar
T 42	205 R 14 C	3,5 bar

Special tyres RAINSTAR T (Optional)

Model	Tyre size	Required Tyre Pressure
T 32	205 R 14 C	3,5 bar
	R 26 x 12.00 - 12	4,5 bar
T 42	R 26 x 12.00 - 12	4,5 bar

17.1 STANDARD TYRES CART RAINSTAR T

Reifendimension	Erforderlicher Reifendruck
165 / 70 R 13	1,3 bar

Machine weights

Model	Type	G	
		Without water kg	with wasser kg
T32	65-270	1400	2060
	65-320	1450	2220
	65-350	1470	2320
	75-250	1460	2260
	75-280	1490	2400
	75-300	1520	2480
	75-330	1550	2620
	85-220	1530	2410
T42	75-350	1650	2780
	85-270	1670	2760
	85-300	1720	2930
	85-320	1750	3050
	90-260	1710	2880
	90-280	1750	3010
	90-300	1790	3140

18 TROUBLE SHOOTING

FAULT	CAUSE	REMEDY
PE-pipe cannot be pulled off.	Gear shift lever in wrong position	Move to pull-off position.
	Brake band sticking on the brake drum.	Loosen brake band.
PE-pipe retraction stops before final shut-off activated.	Turbine blocked by foreign object.	Remove foreign object.
	Pressure drop in supply line.	Check pumping station and water connection at the hydrant.
	Overwinding PE-pipe actuates the safety shut-off.	Adjust the winding mechanism.
Repair broken winding chain.		
Final shut-off activated but the shut-off valve does not close.	Values set for shut-off are not correct.	Adjust setting according to instructions.
	Thin plastic hose of shut-off valve is blocked up or broken.	Replace the plastic hose.
The reel overwinds during pull-off or the PE-pipe windings become loose.	Tractor stopped abruptly.	Slow down gradually.
	Loose brake setting.	Adjust brake.
	No oil in change-speed gearbox.	Refill oil.
Retraction speed varies from one PE-pipe layer to the next.	Varying ground conditions.	Adjust speed control system to the ground conditions (Change rod position on the lever of the layering mechanism.)
The desired retraction speed is not reached.	Incorrect transmission.	Select correct transmission.
	Sprinkler nozzle blocked.	Remove foreign object.
	General: compare supply pressure and water flow with performance chart values.	
Cart is not lifted	Wrong gearbox transmission	Select correct transmission.
Water is running out at the reel supply (flange bow)	Lip seal or sealing bush damaged	Replace affected parts

19 CONFORMITY CERTIFICATE

EC Declaration of Conformity According to EC Directive 2006/42/EG

The manufacturer

Röhren- und Pumpenwerk BAUER Gesellschaft m.b.H.
Kowaldstraße 2, 8570 Voitsberg, Austria
Tel: +43 3142 200-0; Fax: +43 3142 200-320/-340

herewith confirms that the machine component mentioned below

Designation of machine	RAINSTAR
Machine type / basic units	T32, T42, T52, T62
Consists of	Irrigation machine with drum cart

Corresponds analogously to the requirements of the Machinery Directive 2006/42/EC.

In case of a modification of the machine not accorded with BAUER GmbH, this declaration will cease to be valid.

The following standards as amended have been applied analogously:

DIN EN 12100-1	Safety of machines – Basic concepts, general principles for design, Part 1: Basic terminology, methodology
DIN EN 12100-2	Safety of machines – Basic concepts, general principles for design, Part 2: Technical principles and specifications
DIN EN 60204-1	Safety of machines - Electrical equipment of machines, Part 1: General requirements
EN ISO 14121-1	Safety of machines – Risk assessment

Norms relevant for the product

DIN EN 908 Irrigation machines with drum

Person in charge of documentation: **Thomas Theissl, Kowaldstraße 2, 8570 Voitsberg, Austria**



Technical Designer in Charge



Commercial Manager

Voitsberg, 14.1.2013